

IF SMI KNX 24VDC



Art.-no.:
01092510

IF SMI KNX 24VDC

Art.-no.: 01092510

Intelligent motor control for 8 SMI LoVo motors.

Installation and Operating Instructions

Short description

- Option of connecting up to 8 SMI LoVo 24VDC motors to control interior blinds and interior motors
- Compatible with KNX BUS system
- Programmable button and LED for addressing indication on the device
- KNX objects, Up/Down, Step/Stop, shading position, automatic
- Shutter height %, slat %, shutter height status %, slat status %
- Store/Call up scene 1+2, drive status
- Individual and group control via KNX output devices (conform EIS7 Standard or DPT 1.007 and 1.008 described in KNX System Specifications Interworking Datapoint Types)
- Fully synchronised operation of shades also possible in parallel connection

Technical data

Supply voltage:	24VDC
Housing:	REG 2TE
Interface for BUS system:	KNX, Medium TP1
Interface for motor:	SMI
Communication projects:	82
Max. number of group addresses:	114
Max. assignment of group addresses:	162
Operating temperature:	0 °C (32 °F) to +40 °C (104 °F)
Software class:	A
IP class:	IP 20
Degree of contamination:	2
Dimensions (L x W x D):	90 x 35 x 59 mm
Mark of conformity:	CE

Safety precautions



- Contact a professional electrician for installation.
- Check the control system for signs of mechanical damage after unpacking. If you notice any shipping damage, do not start up the control system and notify your supplier immediately.
- The control system should only be used for the purpose specified by the manufacturer (refer to the operating instructions). Any changes or modifications thereof are not permissible and will result in loss of all warranty claims.
- If the control unit cannot be operated without presenting a hazard, it must be switched off and prevented from being switched on unintentionally.
- Turn off the power supply and prevent it from being switched on unintentionally before performing work on any windows, control or sunshades driven by the control system.

Installation

Notes for professional electricians

1. Connect the control in accordance with the wiring diagram.
2. Attach module on the top-hat rail and push until the module audibly clicks into place on the mounting rail.

Wiring diagram

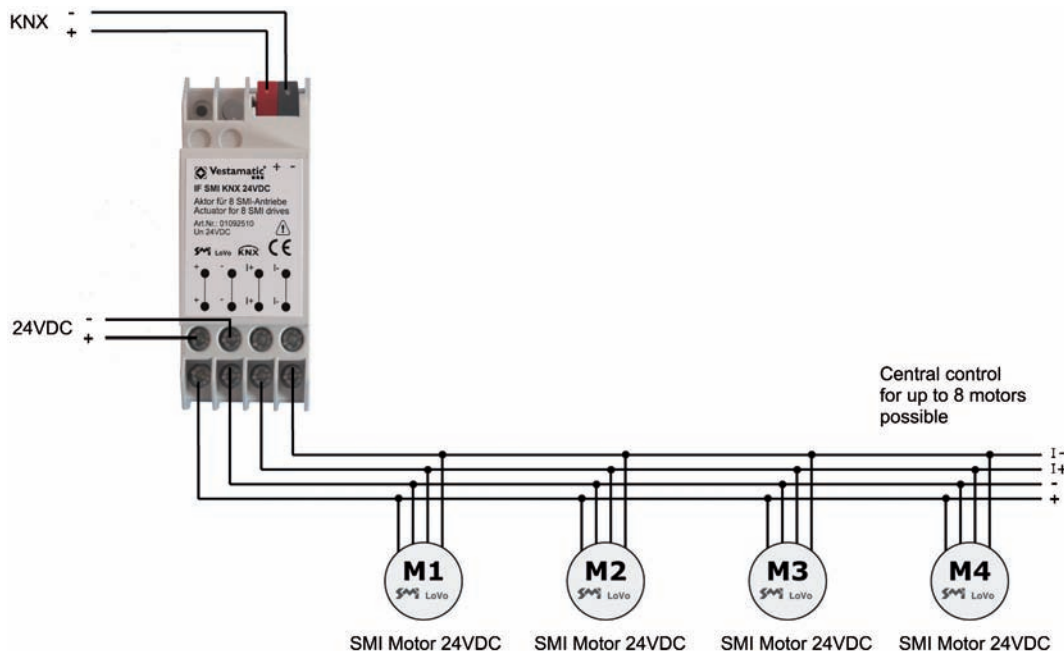

Contents	
What is SMI?	17
General functional description	17
Software and functions	17
Operating states	18
State administration and state table	18
Travel command lock	18
Safety	18
Manual mode	18
Automatic mode	18
State table	19
ETS interface	20
ETS communication objects	21
“Safety” object	22
“Travel command lock” object	22
“Up/Down travel, channel x” object (manual mode)	22
“Stop/Step travel, channel x” object (manual mode)	22
“Sunshade, channel x” object (automatic mode)	22
“Automatic mode, channel x” object	22
“Position of sunshade (%), channel x” object (automatic mode or, if automatic deactivated, manual mode)	22
“Position of slat angle (%), channel x” object (automatic mode or, if automatic deactivated, manual mode – only for blinds)	22
“Status position of sunshade (%), channel x” object	22
“Status position of slat angle (%), channel x” object (only for blinds)	23
“Move to scene pos 1/pos 2, channel x” object (manual mode)	22
“Save scene pos 1/pos 2, channel x” object (manual mode)	23
“Drive error status” object	23
ETS parameters	23–27
Planning and activation	27
Initialisation using drives with slave addresses already programmed	27
Initialisation using drives with non-programmed slave addresses or slave address 0	27
Errors and warnings during initialisation	28
Procedure for planning and activation	28
Options in the case of errors during planning and activation	28
User interface objects and properties (UIO interface)	28
Errors and warnings in properties 201 & 202 in the device object	28
User interface object 50001 and properties therein	29
Property 1, 51, 64 and 65 h	29
Property 80, 81 to 88	30
The SMI software	30

General functional description

SMIdrive 8 is an EIB actuator for the control of up to 8 SMI drives. The drives are independently addressed and controlled via the SMI. The drives are controlled depending on the parametrisation of the actuator and commands received via the EIB. Commands and data are transmitted via the EIB using communication objects. Thus the drives connected to the actuator can be moved independently via the EIB using standard functions such as up/down, step/stop and others. Also, status information such as current shade or slat position (%) and motor errors can be interrogated via the EIB. A determination of prioritised operating states integrates manual and automatic operations as well as those controlled by safety monitors or travel locks.

The parametrisation and activation of the device is carried out via the ETS. The ETS interface presents the project manager with parameters arranged in tabs. The communication objects are tabulated. The addressing of the SMI drives connected to the device is carried out via the ETS activation. The addressing of the drives on the SMI side is either carried out automatically using the slave addresses assigned in the ETS parametrisation or alternatively using SMI key IDs given in the ETS.

On the SMI side, the actuator only uses commands from the SMI standard and is thereby compatible with SMI drives from all manufacturers. The actuator does not functionally support use of manufacturer-specific features. Nevertheless, manufacturer-specific parametrisation of SMI drives can also be carried out via the EIB (see following section).

In addition to ETS parametrisation, a UIO (user interface object) interface can be used in order to obtain access to the internal actuator SMI configuration or directly to the SMI communication via the EIB. Software is available for the practical use of this interface. It is, however, in principle also possible to use this interface with, for instance, the device editor from the ETS3 packet. The UIO interface permits further diagnostics within the context of activation and also subsequent interventions in the parametrisation of SMI drives themselves.

Software and functions

The software of the SMI actuator consists of different units, which divide into the resources available in the actuator hardware (a processor with integrated Flash ROM, RAM and additional EEPROM).

- The EIB operating system of the actuator “System 2” is compatible with the BCU2 standard. It provides the entire interface for hardware resources and applications software (firmware) on the one hand and for EIB on the other. A bootloader in the Flash-ROM of the processor is an integral component of System 2 and permits an exchange of software parts, especially firmware (this is the applications software including SMI communications library) through access via the EIB. The firmware is mirrored in a copy in the EEPROM. Only firmware recognised as valid is copied by the bootloader from the EEPROM into the processor Flash ROM and, if appropriate, implemented.
- An SMI communications library is an integral component of the firmware. It is certified on the part of SMI and constitutes the interface to the SMI and the slaves connected to it.
- The actual applications software uses the remaining actuator memory for the actuator software functionality depending on ETS parametrisation. It also includes the operation of the UIO interface via standardised system functions.
- The ETS interface includes information on EIB communication objects and parameters, which specify the interface with the EIB and the functionality of the actuator. These elements can be configured and loaded into the actuator using the ETS. This information thereby reaches the EEPROM of the actuator and can be read there by the operating system and by the firmware and be evaluated in detail to determine the performance.

Different software tools permit access to specific memories of the actuator via the EIB. In addition to standard development tools, these tools are namely a firmware update tool, which under certain conditions permits an update of the firmware via the EIB, as well as an SMI tool, which using the UIO interface supports diagnoses and direct access to the SMI via a gateway.

The functionality of the firmware and the elements of the ETS surface are firstly described below. Other sections will explain specifics on the activation and the UIO interface.

What is SMI?

SMI is the abbreviation for **Standard Motor Interface**. SMI has been developed for the connection of intelligent drives for roller shutters and sun protection systems. SMI enables to transmit telegrams from control system to the drive and vice versa. With SMI it is possible to combine products from different sources together. The SMI Interface should spread high value solutions and promote drives and controls on the market. The applications in roller shutters and sun protection systems require extreme robustness and economic efficiency. SMI has been developed to meet these requirements.

Operating states

State administration and state table

The actuator basically distinguishes between the following states (in order of decreasing priority):

- 1) Travel command lock
- 2) Safety
- 3) Manual mode
- 4) Automatic mode

The automatic mode can be locked separately for each channel per ETS parameter. In this case, the communication objects for switching between automatic and manual mode and the sunshade objects do not appear. The objects for positioning shade height and slat angle (%) are considered as manual mode objects for all those channels for which the automatic mode is locked; otherwise, they are considered as automatic objects.

The last state, which exists before a disconnection of the (EIB) bus voltage, is restored when the bus voltage is switched back on.

Travel command lock

This state has the highest priority. It prevents all other movements, even those due to a safety object. The purpose of setting a travel command lock is, for example, to protect people who carry out work on automatically moveable shades (window cleaners).

By activating the travel command lock, any ongoing movement of the shade is still followed through; any movement-triggering telegrams that arrive thereafter are no longer executed however.

As long as the travel command lock is active, one of the other states is "masked" active in the background. By lifting the travel command lock, the "masked" state is restored and in case of safety or automatic mode the corresponding movement is also activated if appropriate. The "masked" state is either the last one that existed before activation of the travel command lock or one which was observed by an interim telegram in the background.

If when activating the travel command lock, the actuator is, for example, in automatic mode, incoming automatic travel commands are also stored during the travel command lock and executed after it is lifted. If a safety object with a "1" value occurs during the travel command lock, the "masked" state changes into "Safety" and results in the corresponding movement as soon as the travel command lock is lifted.

Manual mode commands, which occur during a travel command lock, are ignored and do not result in a "masked" change in state either.

Safety

This state has the second highest priority. If a safety object with a "1" value occurs, the state of the actuator changes into "Safety" mode (in the event of existing travel command lock of the "masked" state). If there is no travel command lock, the drive moves to the respective channel's parametrised position for this case. The purpose of the "Safety" state is to protect the shades against wind that is too strong, for example.

By activating the safety function, any ongoing movement of the shade is interrupted and any incoming movement-triggering telegrams are no longer executed.

As long as the safety mode is active, one of the automatic or manual mode states is "masked" active in the background. By lifting the safety state, the "masked" state is restored and in case of automatic mode the corresponding movement is also activated if appropriate. The "masked" state is the last one which existed before activation of the safety function.

Automatic travel commands, which occur in the safety state, are observed and only executed if safety mode and potentially command lock or manual mode are overridden.

Manual mode commands, which occur while in a "Safety" state, are ignored and do not result in a "masked" change in state either.

For those channels for which the automatic mode was deactivated per parameter, an additional parameter can be set for each channel. This parameter can determine that even those positions, which were specified by manual mode-% objects, are restored, after the safety function is discontinued, to how they were before the safety function, or to how they were preset in the "masked" state while the safety function was still active. In the state table on the next page, reference is made to this information in the "Safety off in manual mode without travel lock" field. The corresponding parameter appears in the parameter description.

If the actuator receives a telegram to activate the travel command lock while the safety function is active, the state switches to travel command lock and the "Safety" state is "masked".

Manual mode

This state has the third highest priority. Unless prevented by the travel command lock or safety function, manual commands are executed immediately and also result in a change in state in manual mode in the case of existing automatic mode. A change of manual mode to automatic mode can only be carried out using the automatic object with the value "1".

Automatic mode

This state has the lowest priority. Automatic travel commands are only executed in automatic mode.

State table

The following state table reproduces the transitions between the operating states depending on events occurring (telegrams).
The manual mode state exists if all other operating states (automatic, safety and travel lock) are switched off.

No.	Events											Operating state					
	Travel lock	Safety	Auto-matic	EIB OFF	EIB ON	Travel lock ON object	Travel lock OFF object	Safety ON object or time monitoring	"Safety" object OFF	"Automatic" object ON	"Automatic" object OFF	"Manual mode" object UP/DOWN	"Manual mode" object Step UP/DOWN	Move to scene object	Save scene (motor stands)	Shade/slat % position object	Up/sun-shade object (see note)
0	off	off	off	0 Move to position for Bus OFF	0 Bring current movement to end	0 0	2 Move to safety position	0 0	1 Move to stored shade/slat position	0 0	0 0	0 Step up and down	0 Move to scene	0 Save scene	0 Setpoint position is only stored	0 Setpoint position is only stored	0 0
1	off	off	on	1 Move to position for Bus OFF	5 Bring current movement to end	1 1	3 Move to safety position	1 1	1 1	0 0	0 0	0 Step up and down	0 Move to scene	1 Save scene	1 Movement to and storage of setpoint position	1 Movement to and storage of setpoint position	1 1
2	off	on	off	2 Move to position for Bus OFF	6 Bring current movement to end	2 2	2 2	0 See comment re. safety operating states	3 3	2 2	2 2	2 2	2 2	2 Save scene	2 Setpoint position is only stored	2 Setpoint position is only stored	2 2
3	off	on	on	3 Move to position for Bus OFF	7 Bring current movement to end	3 3	3 3	1 Move to stored shade/slat position	3 3	2 2	2 2	2 2	2 2	3 Save scene	3 Setpoint position is only stored	3 Setpoint position is only stored	3 3
4	on	off	off	4 4	4 4	0 0	6 6	4 4	5 5	4 4	4 4	4 4	4 4	4 Save scene	4 Setpoint position is only stored	4 Setpoint position is only stored	4 4
5	on	off	on	5 5	5 5	1 Move to stored shade/slat position	7 7	5 5	5 5	4 4	4 4	4 4	4 4	5 Save scene	5 Setpoint position is only stored	5 Setpoint position is only stored	5 5
6	on	on	off	6 6	6 6	2 Move to safety position	6 6	4 4	7 7	6 6	6 6	6 6	6 6	6 Save scene	6 Setpoint position is only stored	6 Setpoint position is only stored	6 6
7	on	on	on	7 7	7 7	3 Move to safety position	7 7	5 5	7 7	6 6	6 6	6 6	6 6	7 Save scene	7 Setpoint position is only stored	7 Setpoint position is only stored	7 7

ETS interface

The configuration of the ETS interface (communication objects and parameters) is based on the blind actuators already available on the market. This ensures that the device can be parametrised and activated by the project manager with a minimal period of adjustment.

The parameters are systematically arranged on tabs. In addition to general parameters, which are collectively active for the actuator, the selection of channels or drives to be used and their SMI addressing can be defined on two other tabs. All other tabs, parameters and communication objects are shown or masked out depending on the channels selected and settings carried out. Depending on the default setting, all of the up to eight channels are set as "unused" so that initially only two general communication objects (lock and safety) and no other elements are illustrated for the channels. Other communication objects and parameters only appear for the channels selected as "used".

In the case of common parametrisation for all channels ("all equal"), one tab each for the administration and the mechanics of the channels is shown. Settings on these tabs are active for all channels and drives at the same time. With individual parametrisation, one tab with administration parameters, one with mechanical parameters and the communication objects available for this channel depending on the setting are shown respectively for each channel selected as "used".

Depending on the addressing mode set on the general tab, either a tab for setting only the slave addresses appears (in the case of "automatic" addressing) or two other tabs for registering the manufacturer and the key IDs of the drives used (in the case of "per manufacturer and SMI key ID" addressing).

For those lists of communication objects and parameters reproduced as follows, reference is made in the "Dependent on" column as to which other settings the appearance of the respective element is dependent on. Special reference is, however, no longer made in detail to the basic dependency that channel-specific objects only appear for activated channels.

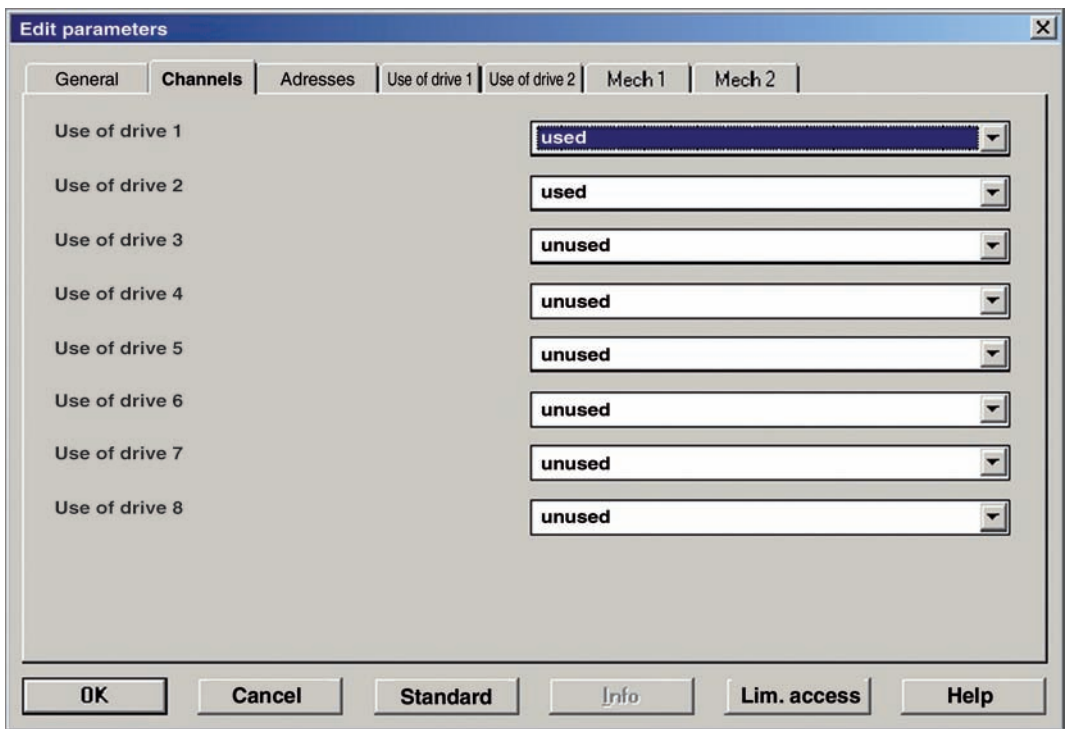

Fig. ETS interface
 ETS2, two channels activated,
 individual parametrisation,
 automatic addressing.

ETS communication objects

Object no.	Object name	Operating mode	Dependent on	Function	Type	Object flags
General objects (active for all channels at the same time)						
0	Safety			On/Off	1 bit	AKS/receive
1	Travel command lock			On/Off	1 bit	AKS/receive
Channel-specific objects channel 1						
2	Up/Down travel, channel 1	Manual mode		Up/Down	1 bit	AKS/receive
3	Stop/Step travel, channel 1	Manual mode		Up/Down	1 bit	AKS/receive
4	Sunshade, channel 1	Automatic mode	Automatic mode released	Up/Down	1 bit	AKS/receive
5	Automatic mode, channel 1		Automatic mode released	On/Off	1 bit	AKS/receive
6	Position of sunshade (%), channel 1	Automatic/manual		8-bit value	8 bit	AKS/receive
7	Position of slat angle (%), channel 1	Automatic/manual	Shade type blind	8-bit value	8 bit	AKS/receive
8	Position of sunshade status object (%), channel 1			8-bit value	8 bit	KLÜ/send
9	Position of slat angle status object (%), channel 1		Shade type blind	8-bit value	8 bit	KLÜ/send
10	Move to scene pos1/pos2, channel 1	Manual mode		Pos 1 / Pos 2	1 bit	AKS/receive
11	Save scene pos1/pos2, channel 1	Manual mode		Pos 1 / Pos 2	1 bit	AKS/receive
12	Drive error status, channel 1			On/Off	1 bit	KLÜ/send
Channel-specific objects channels 2 to 8						
13	Up/Down travel, channel 2	Manual mode		Up/Down	1 bit	AKS/receive
14	Stop/Step travel, channel 2	Manual mode		Up/Down	1 bit	AKS/receive
15	Sunshade, channel 2	Automatic mode	Automatic mode released	Up/Down	1 bit	AKS/receive
16	Automatic mode, channel 2		Automatic mode released	On/Off	1 bit	AKS/receive
17	Position of sunshade (%), channel 2	Automatic/manual		8-bit value	8 bit	AKS/receive
18	Position of slat angle (%), channel 2	Automatic/manual	Shade type blind	8-bit value	8 bit	AKS/receive
...
85	Position of sunshade status object (%), channel 8			8-bit value	8 bit	KLÜ/send
86	Position of slat angle status object (%), channel 8		Shade type blind	8-bit value	8 bit	KLÜ/send
87	Move to scene pos1/pos2, channel 8	Manual mode		Pos 1 / Pos 2	1 bit	AKS/receive
88	Save scene pos1/pos2, channel 8	Manual mode		Pos 1 / Pos 2	1 bit	AKS/receive
89	Drive error status, channel 8			On/Off	1 bit	KLÜ/send

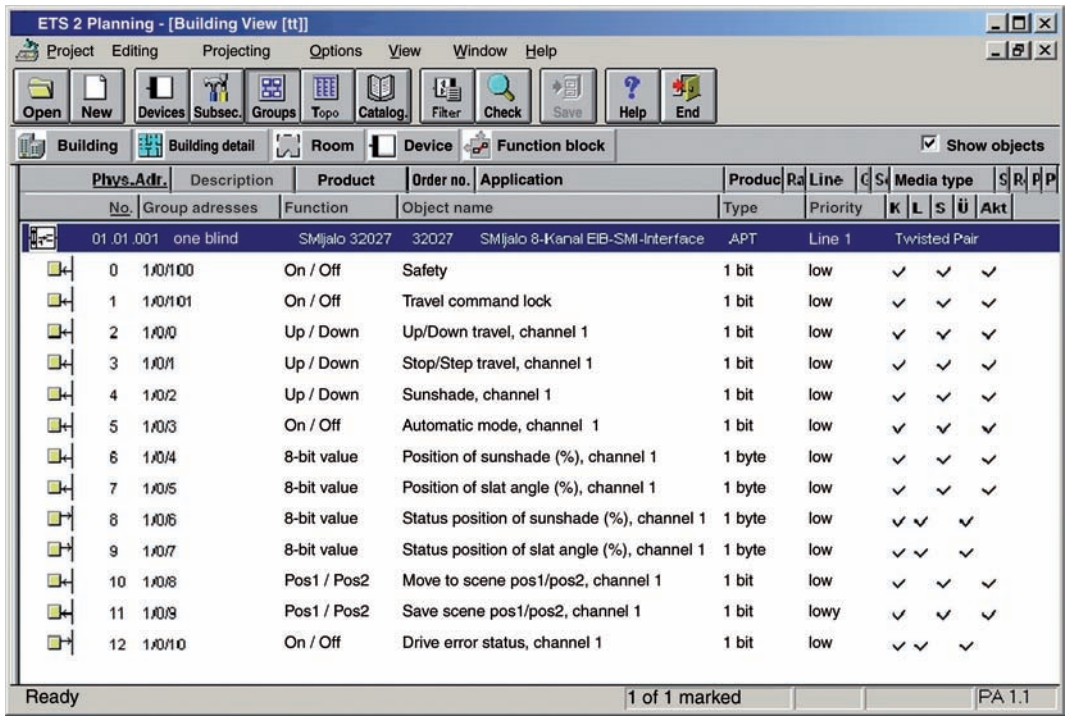

Fig. ETS communication objects in ETS
One channel, blind, with automatic

ETS communication objects
“Safety” object

You can switch the safety function on and off using this object. This object can, for example, be connected to a wind monitoring device. Parameters for each channel can be used to set whether the safety function is released for the channel and how the individual drive should act when the safety function is activated (UP, DOWN or no travel command). The object itself works simultaneously on all channels for which the function is unlocked. If the safety function is switched on and released via the parameters, all incoming travel commands for the channel are locked. The command lock is only overridden after the safety function has been switched off.

- Object value “1”: safety function ON
- Object value “0”: safety function OFF

“Travel command lock” object

You can switch the travel command lock on and off using this object. Via a parameter, you can set for each channel whether the travel command lock is released or locked for the individual channel. The object itself works simultaneously on all channels for which the function is unlocked. If the travel command lock is switched on and released via the parameters, all incoming travel commands for the channel are locked. Any ongoing movement at the time of activating the travel command lock is nevertheless still brought to an end.

- Object value “1”: travel command lock ON
- Object value “0”: travel command lock OFF

“Up/Down travel, channel x” object (manual mode)

You can move the drive into the upper or lower end position using this object.

If “blind” is parametrised as the shade type and the parameter “Adjust upwards after manual downward travel” is set to released, a movement occurs into the lower end position and is followed by an upward adjustment according to the parametrised value for the upward adjustment in the lower position. If the shade is already in the lower position, meaning that the slat may only be closed by further travel, only the slat is closed and the upward adjustment does not occur.

- Object value “0”: travel into the upper end position
- Object value “1”: travel into the lower end position

“Stop/Step travel, channel x” object (manual mode)

You can stop a movement or move the drive by a parametrisable increment using this object.

- Object value “0”: Stop or Step in direction of upper end position
- Object value “1”: Stop or Step in direction of lower end position

“Sunshade, channel x” object (automatic mode)

Use this object to move the drive (similar to the “Up/Down travel, channel x” object) into the upper or lower end position. In addition, after reaching the lower end position, the drive moves (adjusts) in the direction of the upper end position for a parametrisable distance.

This object is only visible if automatic mode is released for the channel.

- Object value “0”: travel into the upper end position
- Object value “1”: travel into the lower end position

“Automatic mode, channel x” object

Use this object to switch the operating mode of the actuator between automatic and manual mode. Corresponding changes of operating mode can also be carried out by other objects using the priority circuit of the operating modes. For this see state administration and state table.

This object is only visible if automatic mode is released for the channel.

- Object value “0”: automatic mode OFF
- Object value “1”: automatic mode ON

“Position of sunshade (%), channel x” object (Automatic mode or, if automatic deactivated, manual mode)

Use this object to position the shade height at a 1-byte value (0–255) scaled to its maximum travel. A slat angle previously set automatically (%) is subsequently restored.

If automatic mode is released for the channel, this object only causes a setting in the case of activated automatic mode; alternatively the object value is stored in the actuator and the position is only approached when the automatic mode is activated again. If automatic mode is locked for the channel, it is interpreted as a manual mode object.

- Object value “0” (corresponds to 0%): travel to the upper end position
- Object value “255” (corresponds to 100%): travel to the lower end position

Interim values are possible.

“Position of slat angle (%), channel x” object (Automatic mode or, if automatic deactivated, manual mode – only for blinds)

Use this object to position the slat angle at a 1-byte value (0–255) scaled to maximum travel. The shade height remains unchanged in the process.

If automatic mode is released for the channel, this object only causes a setting in automatic mode; alternatively the object value is stored in the actuator and the position is approached when the automatic mode is activated again. If automatic mode is locked for the channel, it is interpreted as a manual mode object.

This object is only visible when “blind” is parametrised as the shade type.

- Object value “0” (corresponds to 0%): slat horizontal / open
- Object value “255” (corresponds to 100%): slat closed

Interim values are possible.

“Status position of sunshade (%), channel x” object

Use this object to read out the current shade height (%). It is illustrated scaled at a range of 0–255 (1 byte). The actuator transmits the status spontaneously when the general parameter “Send status objects” is set to “For status change”.

- Object value “0” (corresponds to 0%): position of upper end position
- Object value “255” (corresponds to 100%): position of lower end position

Interim values are possible.

“Status position of slat angle (%), channel x” object (only for blinds)

Use this object to read out the current slat position (%). It is illustrated scaled at a range of 0–255 (1 byte). The actuator transmits the status spontaneously when the general parameter “Send status objects” is set to “For status change”.

This object is only visible when “blind” is parametrised as the shade type.

- Object value “0” (corresponds to 0%): slat position horizontal / open
- Object value “255” (corresponds to 100%): slat position closed

Interim values are possible.

“Move to scene pos 1/pos 2, channel x” object (manual mode)

Use this object to move to positions pos 1 or pos 2 stored in the actuator. With venetian blinds, shade height and slat angle are set; with roller shutters only the shade height is set. Depending on the direction from which the approach is made, the actuator for venetian blinds (using an appropriate movement strategy) ensures that, in the end, both shade height and slat angle correspond to the values at the time the scene was stored.

- Object value “0”: move to pos 1
- Object value “1”: move to pos 2

ETS communication objects

“Save scene pos 1/pos 2, channel x” object (manual mode)

Use this object to store the existing position of shade height and slat angle (for blinds) in the actuator under pos1 or pos2. Storage however only takes place if the drive is standing at the time the telegram is input.

- Object value “0”: store pos 1
- Object value “1”: store pos 2

“Drive error status” object

Use this object to read out a potential drive error. The actuator transmits the status spontaneously when the general parameter “Send status objects” is set to “For status change”.

- Object value “0”: no error
- Object value “1”: error present

i NOTE! Whenever sensible, the actuator software tries to execute simultaneously incoming travel commands (e.g. “Stop/Step travel, channel x”) of several channels (if they are entered with the same group address for instance) also with corresponding SMI group commands for the channels concerned. This ensures the connected drives operate synchronously where possible. In the case of Step commands, the drives are also grouped in accordance with the same value of the step length parameter.

ETS parameters

(Parameter presets are in bold)

Parameter	Setting	Description	Dependent on
“General” tab			
Transmit status objects	only for reading request for status change	Use this parameter to set whether the “position” and “drive error” status objects of all channels can only be read out or whether after reaching a new shade height or slat angle position or upon occurrence or discontinuation of a drive error the corresponding value should automatically be transmitted.	
During bus voltage recovery	send nothing send status objects	Use this parameter to set whether, once bus voltage has been recovered, the “position” and “drive error” status objects of all channels should be transmitted. Transmission occurs, if appropriate, after a time delay which is dependent on the physical address of the actuator, thus avoiding bus conflicts caused by too many actuators transmitting at the same time.	Send status objects = “For status change”
Safety	without time monitoring with time monitoring	This parameter is used to set whether the cyclical reception of telegrams will be monitored over time in conjunction with the safety object.	
Monitoring time for safety	1 minute 5 minutes 10 minutes 30 minutes	If the “Safety” parameter is set to “with time monitoring”, this parameter can be used to set the maximum permitted time between telegrams with a logical zero with regard to the safety object.	Safety = “with time monitoring”
Parametrisation of drives	individual all equal	This parameter allows you to determine whether the channels or drives should be parametrised individually or be made identical. In the case of individual parametrisation, a corresponding parametrisation tab will appear for each channel that is selected as “used”. If the “all equal” setting is used, these tabs and parameters will only appear once and these will then determine the behaviour of all channels together.	
Addressing mode	automatic per manufacturer and SMI key ID	In the case of automatic addressing, the actuator independently programs all configurable drives (those with slave address 0) with the slave addresses designated in accordance with the ETS. The highest SMI slave address is thus assigned to the highest SMI key ID. If addressing is set to occur per manufacturer and SMI key ID, the actuator attributes the slave addresses according to the assignment from the ETS parametrisation.	
Re-addressing	automatic enforce	This parameter can be used to trigger a re-programming of the slave addresses (that have been parametrised according to the ETS) in the drives.	

Art.-Nr.: 84501110 E1 • Vestamatic GmbH • Dohnweg 27 • D-41066 Mönchengladbach • www.vestamatic.com

ETS parameters

(Parameter presets are in bold)

Parameter	Setting	Description	Dependent on
“Channels” tab			
Use of drive 1	unused used	This parameter is used to set whether a drive should be controlled by this channel.	
Use of drive 2	unused used	This parameter is used to set whether a drive should be controlled by this channel.	
...	
Use of drive 8	unused used	This parameter is used to set whether a drive should be controlled by this channel.	

“Addresses” tab			
SMI slave address of drive 1	0, 1, 2, ..., 15	This parameter sets the SMI slave address that is to be used.	Use of drive 1 = “used”
SMI slave address of drive 2	0, 1, 2, ..., 15	This parameter sets the SMI slave address that is to be used.	Use of drive 2 = “used”
...
SMI slave address of drive 8	0, 1, 2, ..., 8 , ..., 15	This parameter sets the SMI slave address that is to be used.	Use of drive 8 = “used”
“Manufacturer” tab			Addressing = “per manufacturer and SMI key ID”
Manufacturer code of drive 1	any , Alcatel, Becker, Elero, Selve, 5, Vestamatic, Varema, 8, 9, ..., 15	If “per manufacturer and SMI key ID” addressing is chosen, the drive manufacturer can be selected using this parameter.	and use of drive 1 = “used”
Manufacturer code of drive 2	any , Alcatel, Becker, Elero, Selve, 5, Vestamatic, Varema, 8, 9, ..., 15	If “per manufacturer and SMI key ID” addressing is chosen, the drive manufacturer can be selected using this parameter.	and use of drive 2 = “used”
...
Manufacturer code of drive 8	any , Alcatel, Becker, Elero, Selve, 5, Vestamatic, Varema, 8, 9, ..., 15	If “per manufacturer and SMI key ID” addressing is chosen, the drive manufacturer can be selected using this parameter.	and use of drive 8 = “used”
“SMI key IDs” tab			Addressing = “per manufacturer and SMI key ID”
SMI key ID of drive 1	SMI key ID of drive (0 ... 4294967295)	If “per manufacturer and SMI key ID” addressing is chosen, the drive can be clearly identified using this parameter in conjunction with the manufacturer code.	and use of drive 1 = “used”
SMI key ID of drive 2	SMI key ID of drive (0 ... 4294967295)	If “per manufacturer and SMI key ID” addressing is chosen, the drive can be clearly identified using this parameter in conjunction with the manufacturer code.	and use of drive 2 = “used”
...
SMI key ID of drive 8	SMI key ID of drive (0 ... 4294967295)	If “per manufacturer and SMI key ID” addressing is chosen, the drive can be clearly identified using this parameter in conjunction with the manufacturer code.	and use of drive 8 = “used”

ETS parameters

(Parameter presets are in bold)

Parameter	Setting	Description	Dependent on
“Administration” tab			Parametrisation of drives = “all equal”
Safety (e.g. wind alarm)	released locked	This parameter can be used to set whether the safety object and the safety function are active for all channels.	
Travel command for safety	no action travel upwards travel downwards	This parameter can be used to determine whether all drives need to travel upwards, travel downwards or keep their position in the event of a safety alarm. Independent of this parametrisation, all incoming travel commands via the EIB are locked if the safety function is released and switched on.	and safety = “released”
Restore positions after all-clear	locked released	If automatic mode is deactivated for all channels, this parameter can be used to indicate that %-positions, which were received as manual mode objects, should be moved to again or moved to subsequently following the safety alarm all-clear.	and automatic mode = “locked”
Travel command lock	released locked	This parameter can be used to set whether the travel command lock is active for all channels. If the lock is released and switched on, all incoming travel commands via the EIB will be blocked.	
Behaviour during bus voltage failure	no action travel upwards travel downwards	This parameter can be used to determine whether all drives need to travel upwards, travel downwards or keep their position during bus voltage failure.	
Behaviour during bus voltage recovery	no action travel upwards travel downwards	This parameter can be used to determine whether all drives need to travel upwards, travel downwards or keep their position when bus voltage is recovered.	
Automatic mode	locked released	This parameter can be used to determine whether all channels support automatic mode. If the “Released” setting is selected, the objects “Sunshade”, “Position of sunshade” and “Position of slat angle” will only be effective if automatic mode is active. Otherwise they will just be stored and only implemented at a later stage when automatic mode is activated. If the “Locked” setting is selected, the objects “Position of sunshade” and “Position of slat angle” will be interpreted as manual mode objects.	
“Mechanics” tab			Parametrisation of drives = “all equal”
Shade type	Blind Roller shutter	This parameter can be used to determine which type of shade is controlled on all channels.	
Factor for the number of degrees of angle for step command (Basis 2°)	0–255 5	This parameter can be used for setting the increment for a step command for all channels.	
Factor for the number of degrees of angle for the adjustment during sunshade positioning (Basis: 2°)	0–255 30	This parameter can be used for determining the angle for adjustment in the lower sunshade position for all channels.	and shade type = “blind”
Number of degrees of angle for upward travel from lower end position (Basis: 2°)	0–255 30	This parameter can be used for determining the angle for upward travel from the lower end position for all channels. This can be used to tauten the cloth of awnings.	and shade type = “roller shutter”
Adjust upwards after manual downward travel	locked released	This parameter can be used to determine whether, for all channels, an upward adjustment by the angle given by the parameter “Adjustment during positioning of lower position” occurs in the case of manual downward travel. An upward adjustment will then also occur if a manual downward movement is interrupted by a stop.	

ETS parameters

(Parameter presets are in bold)

Parameter	Setting	Description	Dependent on
“Mechanics” tab			Parametrisation of drives = “all equal”
Factor for the number of degrees of angle for maximum opened slat position (Basis: 2°)	0–255 45	This parameter is used to determine the angle of the slat position from fully closed to fully opened for all channels.	and shade type = “blind”
Factor for the number of degrees of angle for slat position from open to shade height change (Basis: 2°)	0–255 30	This parameter can be used for all channels to set the angle by which the slats will turn when moving up or when adjusting upwards beyond the fully opened position, before the shade height changes.	and shade type = “roller shutter”
“Admin #” tab (# is channel number 1 ... 8)			Parametrisation of drives = “individual” and use of drive # = “used”
Safety (e.g. wind alarm)	released locked	This parameter can be used to set whether the safety object and the safety function are active for the particular channel.	
Travel command for safety	no action travel upwards travel downwards	This parameter can be used to determine whether the particular drive needs to travel upwards, travel downwards or keep its position in the event of a safety alarm. Independent of this parametrisation, all incoming travel commands via the EIB are locked if the safety function is released and switched on.	and safety = “released”
Restore positions after all-clear	locked released	If automatic mode is deactivated, this parameter can be used to indicate for the particular channel that %-positions, which were received as manual mode objects, should be moved to again or moved to subsequently following the safety alarm all-clear.	and automatic mode = “locked”
Travel command lock	released locked	This parameter can be used to set whether the travel command lock is active for the particular channel. If the lock is released and switched on, all incoming travel commands via the EIB will be blocked.	
Behaviour during bus voltage failure	no action travel upwards travel downwards	This parameter can be used to determine whether the particular drive needs to travel upwards, travel downwards or keep its position during bus voltage failure.	
Behaviour during bus voltage recovery	no action travel upwards travel downwards	This parameter can be used to determine whether the particular drive needs to travel upwards, travel downwards or keep its position during bus voltage recovery.	
Automatic mode	locked released	This parameter can be used to determine whether the particular channel supports automatic mode. If the “Released” setting is selected, the objects “Sunshade”, “Position of sunshade” and “Position of slat angle” will only be effective if automatic mode is active. Otherwise they will just be stored and only implemented at a later stage when automatic mode is activated. If the “Locked” setting is selected, the objects “Position of sunshade” and “Position of slat angle” will be interpreted as manual mode objects.	

ETS parameters

(Parameter presets are in bold)

Parameter	Setting	Description	Dependent on
“Mech #” tab (# is channel number 1 ... 8)			Parametrisation of drives = “individual” and use of drive # = “used”
Shade type	Blind Roller Shutter	This parameter can be used to determine which type of shade is controlled on the particular channel.	
Factor for the number of degrees of angle for step command (Basis 2°)	0–255 5	This parameter can be used for setting the increment for a step command for the particular channel.	
Factor for the number of degrees of angle for the adjustment during sunshade positioning (Basis 2°)	0–255 30	This parameter can be used for determining the angle for adjustment in the lower sunshade position for the particular channel.	and shade type = “blind”
Factor for the number of degrees of angle for Up travel from lower end position (Basis 2°)	0–255 30	This parameter can be used for determining the angle for upward travel from the lower end position for the particular channel. This can be used to tauten the cloth of awnings.	and shade type = “roller shutter”
Adjust upwards after manual downward travel	locked released	This parameter can be used to determine whether, for the particular channel, an upward adjustment by the angle given by the parameter “Adjustment during positioning of lower position” occurs in the case of manual downward travel. An upward adjustment will then also occur if a manual downward movement is interrupted by a stop.	
Factor for the number of degrees of angle for maximum opened slat position (Basis: 2°)	0–255 45	This parameter is used to determine the angle of the slat position from fully closed to fully opened for the particular channel.	and shade type = “blind”
Factor for the number of degrees of angle for slat position from open to shade height change (Basis: 2°)	0–255 30	This parameter can be used, for the particular channel, to set the angle by which the slats will turn when moving up or when adjusting upwards beyond the fully opened position, before the shade height changes.	and shade type = “blind”

Planning and activation
Initialisation using drives with slave addresses already programmed

During initialisation (after bus reset, switch-on or download), the actuator attempts to reference the available slaves, assigned per channel according to the ETS parametrisation, using their SMI slave addresses. If the actuator has already been taken into operation, it will have stored the manufacturer and key ID entries for all the available drives in its non-volatile memory.

For each slave expected according to the ETS and found on the SMI, the manufacturer and key ID entries are read out and compared with the stored entries. If “per manufacturer and SMI key ID” addressing has been chosen, a comparison occurs simultaneously with the drive data given in accordance with the ETS. If no physical change has occurred to the slaves available on the SMI since the last activation, the actuator is then immediately ready for operation.

If one or more drives have been exchanged in the meantime, the new drives will answer but using the relevant slave address from the outset. This means that, in the case of automatic addressing, manufacturer and key ID entries that are detected as different by the actuator will be updated and stored. In the case of key ID addressing, the drive data given in accordance with the ETS must correspond to the data read out; otherwise the drives will not be accepted by the actuator and will be ignored during operation.

On all channels that are configured as blinds, a calibration will then be carried out for drives identified as exchanged. For this, the actuator initiates an adjustment of the drive by a fixed angle of 500° in order to ascertain the ratio of SMI positions in degrees by using the previously and subse-

quently read out SMI positions. Moreover, this will be used to position the blind slats so that shading situations can be recreated exactly, non-directionally and directly; the parametrisation of the slat geometry can be given, however, in °.

Even during initial activation with drives with ready pre-programmed SMI slave addresses, again no further programming of slave addresses is needed, just a calibration of the drives if necessary.

Initialisation using drives with non-programmed slave addresses or slave address 0

If, during initialisation, no drives answer at one or more addresses preset in accordance with the ETS, the actuator attempts to assign the missing slave addresses to drives by re-programming. In this case there are two possible addressing processes:

In the case of automatic addressing, the actuator uses the algorithm for key ID search, as specified in the SMI standard. If the actuator finds a programmable slave (slave address 0), it will program the slave with the slave address designated in accordance with the ETS. The highest key ID found of the programmable drives will be assigned to the highest unallocated slave address in accordance with the ETS.

In the case of key ID addressing, the actuator attempts to program those drives with the unallocated slave addresses, the manufacturer and key ID data of which are assigned to the slave address in accordance with the ETS. If this attempt fails, the channel with this slave address remains without function.

Planning and activation
Errors and warnings during initialisation

Irrespective of the mode of addressing, the actuator will generate corresponding error codes if an assignment attempt is unsuccessful. Warning codes are generated if, for instance, slaves are reprogrammed or it is identified that slaves have been exchanged. The 6 last different errors and warnings are stored each in a property in the device object of the actuator. Property 201 (hex C9) contains the warnings; Property 202 (hex CA) contains the errors. The corresponding table of errors and warnings in properties 201 & 202 in the device object displays the possible error and warning codes and their causes.

Procedure for planning and activation

The basic addressing modes of “automatic” and “per manufacturer and SMI key ID” should be selected according to whether the drive data (manufacturer and key ID) of the drives can be or has been recorded by the installer during installation.

Many manufacturers help here by supplying the drives, the shades or the cable with peelable stickers detailing the drive’s key ID. If the drive data is clearly assigned to the drives’ installation locations, the setter can usually carry out the activation through “per manufacturer and SMI key ID” addressing with a single ETS download per actuator. This process also has the advantage that all drive data is then documented in the ETS project.

In all other circumstances, “automatic” addressing should be used, which may require appraisal of the initial random assignment after the first download. After the slave addresses have been re-sorted in the ETS and following a new download, the assignment is complete.

Even if the drives have been programmed with known slave addresses, these can be entered straight into the ETS. If the spatial distribution of the drives with these addresses is known from the outset, the assignment via the channels can be set with similar precision. If the position of the drives is not known, this can be determined after the initial ETS download through operation via the EIB and then re-sorted.

If preprogrammed drives or partly pre-programmed, partly non-preprogrammed drives are used with unknown slave addresses, the actuator can be initiated with the re-addressing = “enforce” parameter in order to pre-program all slaves with the slave address 0. Thereupon the actuator will program all connected slaves, according to the selected mode of addressing, with the slave addresses given in the ETS. Whether the channel assignment is then complete depends on the addressing procedure (see above).

Options in the case of errors during planning and activation

If, during a full re-addressing process, more key IDs (i.e. slaves) have been found than there are slave addresses available according to the ETS parametrisation, the remaining drives (key IDs) keep the slave address 0. Alternatively, if fewer key IDs are found than there are slave addresses available according to the ETS parametrisation, no drives will be assigned to the remaining slave addresses or channels – the channels remain without function.

Other possible errors during activation may be identified, whereby the properties 201 and 202 are read out from the device object (if appropriate with the Device Editor from the ETS 3 accessories).

In the same way, the properties in the user interface object 50001 can be checked and interpreted using the description outlined further below. Please refer to “User interface object 50001 and properties therein”. The SMI Tool is a diagnostic aid with very wide-ranging possibilities. It will make access to individual actuators and the corresponding properties of the user interface object 50001 much easier (see the following).

User interface objects and properties (UIO interface)

The user interface objects and properties have an interface which enables (via the EIB through use of appropriate tools) further diagnoses, settings and interventions, particularly on the SMI side at the particular actuator. The use of the UIO interface is possible either via a standard tool such as the Device Editor from the ETS3 accessories, or via a special tool that can be used independently of the ETS but is used for the communication with the particular actuator from the Falcon library and the EIB. The free software assumes that the Falcon library (an integral component of, for example, ETS3) is available.

However, the use of the UIO interface with, for instance, the Device Editor requires the user to have special knowledge and a certain degree of experience. This chapter should therefore be read thoroughly and understood. It is recommended that use with the Device Editor is reserved only for emergencies, for instance for the diagnosis of otherwise inexplicable faults. It is much simpler to use the UIO interface with the SMI tool (see “The SMI software”).

The actuator software supports, in addition to the interface objects set out in the EIB standard, another object with the ID “50001”, which supports diagnosis and provides certain setter functionality for the actuator-connected SMI bus and its devices. The above-mentioned software visualises the properties provided via the user interface object 50001, thus enabling a clear diagnosis. The software provides a practical way of intervening in the SMI addressing of slave drives and in their parametrisation.

Essentially it is also possible to access the SMI drives directly and to transmit any conceivable SMI command to the individual connected slaves through the particular actuator acting as an SMI gateway. This is where property 64 is used. As access is provided via the EIB, no hardware connection to the particular SMI bus is required. Communication is conveyed, via the physical address of the actuator concerned in the EIB, to the appropriate SMI bus. Of course, drives may also be parametrised physically.

Errors and warnings in properties 201 & 202 in the device object

The actuator’s EIB operating system “System 2” provides further properties (in addition to those specified in the KNX standard) in the device object that are partially co-used by the actuator’s application firmware. In particular, the properties 201 and 202 in the device object allow access to errors and warnings, thus supporting a diagnosis in the event of faults.

Also written in these properties by the operating system are, if appropriate, warnings or errors. The latter have codes \leq hex 6F and are described in the documentation on System 2; those of the application of the actuators have codes \geq hex 70 and are summarised in the following table.

Code	Type	Description	Cause
0x73	Error	SMI transmission time-out	Error in SMI communication during transmission, possibly no SMI power.
0x74	Error	EEPROM error	Data error in EEPROM (checksum faulty), ETS download may be faulty.
0x76	Error	Slave programming error	An attempt to program a slave has failed.
0x77	Error	Slave address duplicated	A slave address has been assigned twice (same for two channels) in the ETS.
0x78	Warning	Unknown slave	A slave has been found that is not present in the ETS parametrisation.
0x7a	Warning	EEPROM updated	One or more new or exchanged slaves have been identified.
0x7b	Warning	Enforced new programming	All slaves are re-programmed according to ETS parameters.
0x7c	Warning	Missing slaves	It has not been possible to assign all the slaves that, according to the ETS, should be available.
0x7d	Warning	Incorrect key ID ignored	A slave is ignored because it has a different key ID to the one expected according to the ETS.

User interface objects and properties (UIO interface)
User interface object 50001 and properties therein

The properties defined in user interface object 50001 are displayed and explained in the following table.

Prop ID	Data type	Length	R/W	Memory	Function
1	Obj-ID	2 byte	RO	Code	Object ID of the user interface object, fixed "50001"
51	Version	2 byte	RO	RAM	Internal firmware version
64	char[17]	17 byte	R/W	RAM	Gateway for SMI commands
65	char[8]	8 byte	RO	RAM	Status of channels 1 to 8
80	int	2 byte	RO	EEPROM	Mask of available slaves
81	char[6]	6 byte	RO	EEPROM	Channel no. / Type / Manufacturer ID / Key ID of slave 1
82	char[6]	6 byte	RO	EEPROM	Channel no. / Type / Manufacturer ID / Key ID of slave 2
...
87	char[6]	6 byte	RO	EEPROM	Channel no. / Type / Manufacturer ID / Key ID of slave 7
88	char[6]	6 byte	RO	EEPROM	Channel no. / Type / Manufacturer ID / Key ID of slave 8

Property 1

Property 1 displays the object ID in accordance with the KNX standard and is read-only.

Property 51

Property 51 uses the 2-byte-long data type PDT_VERSION specified in the KNX standard and allows the internal firmware version to be read out. During initialisation, the firmware always produces a RAM copy of the software version identifier permanently coded in the processor Flash; this identifier cannot be externally altered. Each nibble in the 2-byte value has its own significance: the highest value gives the major version number, the second highest the minor version number and the two lower-value nibbles give an additional sub- and sub-sub version numbering. In the version identifier communicated with clients, the second lowest nibble is given as a letter, whereby value 1 corresponds to "A". The version 2232h therefore corresponds to "02.02 C 2".

Property 64

Property 64 acts as a gateway to the SMI bus – it is therefore bidirectional, which means that it is both externally readable and writable. With a length of 17 bytes, it enables the transmission of any SMI commands which the actuator passes on unchanged to the SMI bus. These could be, according to SMI specification, a maximum of 16 bytes long, with a start byte and up to three blocks, each made up of one identifier byte with up to four parameter bytes. When an SMI command is given via writing of the property 64, there is no need for a checksum to be appended to the telegram – this is accepted by the actuator before relaying to the SMI bus. Instead, an additional byte (the one standing on the left – with index 0 according to KNX definition) is provided as a control byte for regulating the data exchange via the gateway property.

The control byte also enables the triggering of special actuator reactions. It can be written with the following values:

Value	Function
00	Software reset of the application, i.e. re-initialisation of the actuator
01	SMI command in the additional 16 bytes for transmission to the SMI bus
02	Re-calibration of all slaves configured as blinds
03	Re-calibration of an individual slave, slave address in the follow byte (this command may not be available depending on the software version).
04	Software reset of the application, i.e. re-initialisation of the actuator, but without previously updating the position data in the EEPROM.
08	Output of values of all properties in the user interface object 50001 to the diagnosis interface.

If the control byte is written externally with the value 01h, the actuator will then interpret the following 16 bytes as an SMI telegram which is to be sent to the bus. The actuator generates the checksum and relays the telegram on, if necessary also with the required retransmissions according to the SMI standard.

All the values detailed in the table above that can be written into the control byte (except 00h and 04h for initialisation) are also immediately acknowledged by the actuator in the control byte. Due to continuous read

out of the byte, it is therefore possible to determine the processing status of the particular request. Here, just as is the case for the SMI standard, the FFh value is essentially interpreted as ACK.

In the case of re-initialisation through the value 00h or 04h, it is possible to change the assignment of slave drives to actuator channels. The properties 65 and 80 to 88 are then updated accordingly. The actuator will let the 0 in the control byte of property 64 stand until the initialisation is complete and then replace it with the value FFh. This way, the completion of the initialisation and therefore the time of the validity of the updated properties 65 and 80 to 88 are discernible externally.

Initially, the actuator acknowledges a re-calibration request in the control byte with the value 12h. The ACK through the value FFh is only set once the re-calibration is complete. Depending on the number and type of connected drives, the calibration can take some time.

Once an SMI telegram has been transmitted to the SMI bus, the actuator sets the control byte initially to the value 80h in order to signal that the telegram has been sent on the SMI side. As soon as there is a communication event (i.e. a slave responds or not), the actuator writes the event of the communication into the property 64. The slave response, beyond ACK or NAK, is contained, if appropriate, in the bytes from index 1 upwards and in the control byte (see values in the following table):

Value	Meaning
FFh	Slave has responded with ACK
E0h	Slave has responded with NAK
70h	Internal error in the communication (should not occur)
7Dh	SMI bus without function due to power failure
7Eh	Communication error on the SMI bus (slave response could not be decoded)
7Fh	SMI communication is still not initialised (an SMI telegram may have been transmitted too quickly following an actuator reset)

Property 65h

Property 65 reflects the current state of channels 1 to 8, as updated by the actuator, and is not amendable externally. The channels 1 to 8 are assigned from left to right to the byte indices 0 to 7. The meaning of the bytes is as follows:

Value	Meaning
00h	Drive present, error-free and travelling UP
01h	Drive present, error-free and travelling DOWN
02h	Drive present, error-free and at rest
03h	Drive present, error-free, movement status still unclear
04h	Drive error
08h	Error: SMI not yet initialised
10h	Error: drive response NAK
20h	Error in the SMI communication
40h	Error: SMI power is off
8Fh	No drive is assigned to this channel
9Fh	Drive, which should be assigned to this channel, has not been found
AFh	No programmable drive has been found for this channel
FFh	Channel not yet checked

The error bits 04h to 40h may theoretically also occur in combination.

User interface objects and properties (UIO interface)
Property 80

The property with the ID 80 is only readable and reproduces the mask of the SMI slaves found in a form that they would also use in group addressing according to the SMI standard, were all drives referenced together.

Properties 81 to 88

The 8 properties with the IDs 81 to 88 reproduce (only readable externally) the presence status which is ascertained after initialisation by the actuator at the SMI bus, in other words the data of the particular slave drive identified. Here, the end numbers of the property ID (1 ... 8, regardless of whether read hexadecimally or decimally) correspond to the number of the channel to which the slave has been assigned according to ETS parametrisation.

The following information is coded in the 8 bytes of each of these properties in sequence:

Byte Index	Meaning
0	Number of the channel to which the drive has been assigned during initialisation.
1 high-Nibble	Drive type ID according to SMI standard (manufacturer-specific)
1 low-Nibble	Manufacturer ID according to SMI standard
2 ... 5	Key ID of the drive according to the SMI standard (read from left to right, the highest-value byte at the position with the smallest index / manufacturer-specific)
6 ... 7	Value of the relative SMI position difference which is determined during calibration. If the channel has not yet been calibrated, but has been configured as a blind, FFFFh appears (0000h if configured as a shutter).

The SMI software

Accessing properties in the user interface object 50001, with the help of Device Editor from the ETS3 bundle, is relatively laborious and time-consuming, and it requires both a certain degree of practice and a precise knowledge of the above-described properties and their individual meanings.

In particular, SMI telegrams, which should be transmitted to SMI slaves via the gateway property 64, must be previously assembled manually and entered in hexadecimal notation byte-by-byte. Using the Device Editor it is practically impossible to track closely the development of property values which are continuously adapted by the actuator to each situation, for instance the state of movement bytes in property 65. This is because values can only be read in again with the whole object, each one taking some time.

In addition, it is the software and not the licensing of the Device Editor that comes as standard in the accessories bundle of ETS3. If property values also need to be altered (written into the actuator) using the Device Editor, an extended licence for ETS3 must be acquired if the manufacturer functions of ETS3 are not already co-licensed.

All these restrictions should be remedied with the SMI software. The SMI tool is a diagnostic aid with very wide-ranging possibilities. It will make access to individual actuators and the corresponding properties of the user interface object 50001 much easier.

Once the list of physical addresses of all the SMI actuators available in the EIB is imported, an individual actuator and its connected SMI bus can be easily selected. The list itself can be directly exported from the ETS, or even edited manually with an ASCII editor.

After an individual SMI actuator has been selected, the read-only values of properties 65, 80 and 81 to 88 are displayed clearly in tabular form. The individual values of property 65 are continuously updated and are constantly visualised in a clear assignment to the drive IDs.

Work with the gateway property 64 is then made considerably easier. Any commands can be entered as hex strings and the processing and response status is tracked in real time. Simple SMI standard commands can be transmitted with clear addressing of individual drives by just clicking special buttons. For example, the physical identification of individual drives whose key ID was previously unknown and was only read out with the SMI tool from the properties 81 to 88 is made far simpler.

Likewise it is also possible to use special buttons to trigger the special re-initialisation or calibration commands, transmissible via the control byte in property 64.

Another feature can be added to the SMI tool, if requested by future users: on an additional tab, a key ID scan on the SMI can be carried out by the SMI tool via the gateway property 64 in the user interface object 50001. Here, the SMI tool uses the same addressing algorithm as the SMI drive 8 actuator during automatic addressing. Up to eight of the found slaves are programmed with the slave addresses 1 to 8, whereby the address 8 is assigned to the highest found SMI key ID and slave address 1 is assigned to the lowest. As the actuator itself only functions in this process as a gateway and is otherwise unoperational, it is recommended to allow a re-initialisation so that the internal actuator data on the slaves is updated accordingly.

The SMI tool is already available as a beta version and from the end of March 2008 (in time for the Light + Building 2008 trade fair) will be downloadable as a final release from the APT website.

For APT GmbH, the extent to which the SMI tool will be upgraded with additional features in future is dependent on the further development and distribution of SMI technology and, finally, customer requirements. Support, for instance, for the transmission of prepared sequences or of whole manufacturer-specific parameter sets directly to individual drives has been contemplated, but has not, for the moment, been implemented.

The disposal of electrical equipment and batteries in household waste is strictly forbidden.

 The symbol (dustbin crossed out, in line with WEEE Appendix IV) indicates separate collection of electrical and electronic products in EU countries. Do not dispose of the device or battery in your household waste. Ask your town or local council about the return and collection systems available in your area to dispose of this product.