



Art.-no.:
01078720

Professional sensor device for buildings.

Installation and Operating Instructions

Short description

- Central connection device for wind, Lux and temperature sensors
- Radio-controlled clock reception – coming soon!
- For use with the Vesta Building Controller or Vesta Building Controller Compact
- BUS communication between the Vesta Building Controller / Vesta Building Controller Compact and sensor box

Technical data

Power supply:	230VAC, 50 Hz
Impulse voltage withstand level:	2.5 kV
Rated power:	2 W (without sensors)
Software class:	A
Operating temperature:	-20°C (-4°F) to +40°C (104°F)
IP class:	IP 54
Degree of contamination:	2
Dimensions (L x W x H):	170 x 135 x 85 mm (without connections))
Mark of conformity:	CE

Safety precautions



- Contact a professional electrician to install the control system, because the control system requires a power supply of 230VAC, 50 Hz.
- Check the control system for signs of mechanical damage after unpacking. If you notice any shipping damage, do not start up the control system and notify your supplier immediately.
- The control system should only be used for the purpose specified by the manufacturer (refer to the operating instructions). Any changes or modifications thereof are not permissible and will result in loss of all warranty claims.
- If the control unit cannot be operated without presenting a hazard, it must be switched off and prevented from being switched on unintentionally.
- Turn off the power supply and prevent it from being switched on unintentionally before performing work on any windows, control or sunshades driven by the control system.

Assembly and installation



WARNING!

Risk of injury due to improper installation and commissioning. Improper installation and commissioning may lead to personal injury or property damage.

Therefore:

- When connecting the device, observe the currently valid VDE standards (in particular DIN VDE 0100/0700), your local power company's regulations and the current accident prevention regulations.
- Connect the control in accordance with the wiring diagram.

Notes for professional electricians

1. Switch off the power supply.
2. Unscrew the housing cover, take off the housing cover and mount the housing at the outer four drill holes in the corners. The housing must be mounted such that the cable inlets are located underneath. The sensor box must be mounted in a position that is well protected from direct sunlight.
3. Feed the cables through the bottom cable inlets in the housing and tighten the inlet. Unused cable inlets must be sealed.
4. Connect the cables in accordance with the wiring diagram.



NOTE!

Mount the sensor box so that it is inaccessible to adults, children and animals. All cables must be permanently wired.

5. Replace the housing cover and tighten the housing cover screws.

Wiring diagram

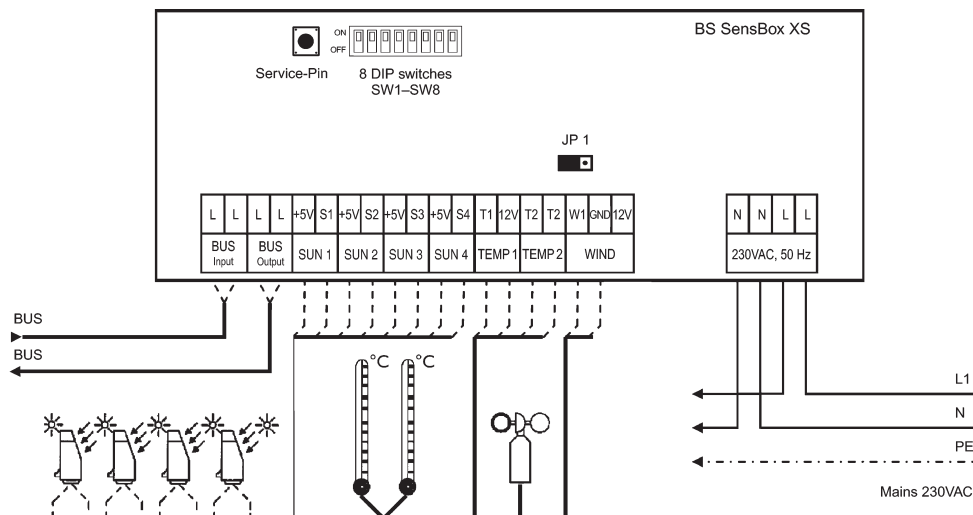

Start-up

Before start-up, the Sensorbox must be configured by means of jumper JP 1 and DIP switch SW1 up to SW8. Please find the description of all settings in section "Configuration".

After switching the operating voltage on or making any changes, push the service pin for 5 seconds to store the settings. A red LED will briefly flash to confirm the changed settings.

Functional description

As an integral component of the Vestamatic system, Sensorbox is a decentralized point of connection for wind, Lux (sun) and temperature sensors. The Sensorbox may only be used when connected to at least one Vestamatic BUS compatible central controller (e.g. Vesta Building Controller).

During installation or start-up, all settings required for the Sensorbox can be carried out by means of a jumper and 8-pole DIP switch. Please find further details in the section "Configuration".

Connecting each sensor

The following Vestamatic sensors can be connected to the Sensorbox:

- 4 Lux sensors, type LS 30
- 2 Temperature sensors, type TS Pro XL
- 2 Wind sensors, type WS Classic M, WS Pro XL, WS XS Tube or WS XS



IMPORTANT!

Heated sensors need an external power supply.

Lux sensors

Up to 4 Lux sensors can be connected to the Sensorbox terminals. The first sensor is to be connected to terminals SUN1 and +5V. The second sensor is to be connected to terminals SUN2 and +5V etc.

In order to connect the sensors with one 5-core cable, the supply voltage for the sensors can be jointly connected (terminals +5V).

After changing the settings, the service pin must be activated for 5 seconds in order to store the changes. A red LED will briefly flash to confirm the changed settings.

Temperature sensors

Up to 2 temperature sensors TS Pro XL can be connected to the Sensorbox terminals. The first sensor is to be connected to terminals TEMP1 and 12V. The second sensor is to be connected to terminals TEMP2 and 12V.

In order to connect two sensors with one 3-core cable, the supply voltage for both sensors can be jointly connected (terminals 12V).

Wind sensor

One wind sensor with digital or analog output can be connected to the Sensorbox.



WARNING!

Before connecting the wind sensor, position the Jumper JP1 according to the following table:

JP 1	right	left
	Wind sensor Analog output Type WS Pro XL	Wind sensor Digital output Type WS Classic M WS XS Tube oder WS XS

Connect wind sensors with analogue or digital outputs to terminals W1 and GND.

After changing the settings, activate the service pin for 5 seconds to save the settings. A red LED will briefly flash to confirm the changed settings.

Configuration

DIP switches

Use the DIP switches SW1–SW8 to set the domain address, base address and transmission frequency of the sensor dates.

Setting the domain address

In order to ensure that all nodes in the Network can communicate, they must have the same domain address.

Please note, that the network always uses two adjacent domain addresses.

If other BUS systems are operated in the same network, the domain selected for the network, must be unique and not used by any other system. Otherwise, correct function of the network and/or other components cannot be guaranteed.

The default setting for the Sensorbox is domain 00/01.

SW1	SW2	SW3	Domain [0]	Domain [1]
OFF	OFF	OFF	00	01
OFF	OFF	ON	32	33
OFF	ON	OFF	64	65
OFF	ON	ON	96	97
ON	OFF	OFF	128	129
ON	OFF	ON	160	161
ON	ON	OFF	192	193
ON	ON	ON	224	225

Setting the base address

The Sensorbox number is assigned by the base address. That way, several Sensorboxes can be operated with the same domain address.

SW4	SW5	SW6	Base address
OFF	OFF	OFF	1 (basic setting)
OFF	OFF	ON	2
OFF	ON	OFF	3
OFF	ON	ON	4
ON	OFF	OFF	5
ON	OFF	ON	6
ON	ON	OFF	7
ON	ON	ON	8

Setting the transmission frequency

The data transmission frequency can be set with SW7 – SW8 of DIP switches.

SW7	SW8	A protocol is transmitted every
OFF	OFF	Never
OFF	ON	0.5 s
ON	OFF	1.0 s
ON	ON	1.5 s



The disposal of electrical equipment and batteries in household waste is strictly forbidden.

The symbol (dustbin crossed out, in line with WEEE Appendix IV) indicates separate collection of electrical and electronic products in EU countries. Do not dispose of the device or battery in your household waste. Ask your town or local council about the return and collection systems available in your area to dispose of this product.