

8150 002 GB 5016 A01

VL-ME-WISO-230-45 VRS



Vestaline
VRS-Line motors

VL-ME-WISO-230-45/10Nm VRS
VL-ME-WISO-230-45/20Nm VRS

Art.-no.: 01066231
Art.-no.: 01066241

Vestaline motors for controlling sunshades.

Installation and Operating Instructions

CONTENTS

1. Safety precautions (safety measures)
2. Short description (identification of products)
3. Scope of delivery
4. Intended use
5. Technical data
6. Installation, Assembly, Disassembly
7. Troubleshooting
8. Warranty
9. Maintenance
10. Disposal of waste
11. Service/Contact
12. Declaration of conformity

1. Safety precautions



WARNING!

Important safety information.
Follow these instructions to ensure the safety of persons. The instructions must be stored.

- Contact a professional electrician to install the motor, because the motor requires a power supply of 230VAC, 50 Hz.
- Check the motor for signs of mechanical damage after unpacking. If you notice any shipping damage, do not start up the motor and notify your supplier immediately.
- The motor should only be used for the purpose specified by the manufacturer (refer to the operating instructions). Any changes or modifications thereof are not permissible and will result in loss of all warranty claims.
- Technical data can be found on the type label of the tubular motor.
- If the motor cannot be operated without presenting a hazard, it must be switched off and prevented from being switched on unintentionally.
- When performing work on the windows, motor or connected shades, protect them against unauthorised or unintentional operation.

- Moving parts of the motor installed under 2.5 m above the floor level should be protected.
- This device is not intended for use by persons (including children) with reduced physical, sensory or mental abilities or lack of experience and/or lack of knowledge, unless they are supervised by a person responsible for their safety, or received instructions on how the device is to be used.
- Children should be supervised to ensure that they do not play with the device.
- Children are not allowed, to play with fixed controls. Keep remotes away from children.
- The installation has to be checked frequently for imbalance or of signs of wear, damaged cables or springs, if applicable.
- Automatically controlled awnings have to be disconnected from the supply network, e.g. if maintenance work has to be done close to them.
- Before the motor is installed, all unneeded wires must be removed and all devices which are not required for actuation with a power drive must be put out of operation.
- The actuating element of a hand release is to be installed at a height of less than 1.8 m.
- The mains cable of this device cannot be replaced. If the mains cable is damaged, the device has to be discarded.



ATTENTION!

Pay attention to the following European guidelines:

- The cables must conform to the applicable VDE standard.
- If installing motors with a PVC H05VV-F cable, the cable on surface-mounted outdoor installations and recessed-mounted installations must be protected by a cable conduit or cable duct.
- When installing the motor an all-pole disconnection with a contact gap of at least 3 mm per pole must be provided.
- The up and down directions of the switch resp. button must be electrically or mechanically locked against each other. The changeover time for changing the running direction (up/down) must be at least 0.5 sec.



WARNING!

Risk of injury due to improper installation and commissioning.

Improper installation and commissioning may lead to personal injury or property damage.

Therefore:

- When connecting the device, observe the currently valid VDE standards (in particular DIN VDE 0100/0700), your local power company’s regulations and the current accident prevention regulations.
- Connect the motor in accordance with the wiring diagram.
- It is important for the safety of professional electricians to follow the user instructions. Please keep instructions for reference.



ATTENTION!

- Follow the safety instructions according to EN 60335-2-97.
- Additional components for the implementation of the installation, such as adapters and brackets must be chosen among those offered by the producer. These products are listed in the catalogue supplied on request.
- When mounting the drive always use the safest and most suitable tubular motor and mounting bracket.
- For automatically actuated awnings a minimum gap of 0.4 m to other parts in the area must be maintained when the awning is fully extended. By using as an awning system the extended awning must maintain a minimum height of 1.8 m.



IMPORTANT!

Any screws used to fix the rolling shutters tube/awnings must in no way touch the motor. Please refer to fig. 4.1 to 4.5.

2. Short description

- Motor 45 mm tube diameter for sunshades
- Programmable upper and lower limit position
- Limit positions can be virtual or physical (upper position)
- Parallel connection allowed
- User-friendly operation in switch mode with standard buttons and/or via VRS radio transmitter
- Intermediate positions storage
- Anti-block function
- Simple setting of the limit position with the “VL-Progset-ME/SMI-230” (Art.-no.: 54185775)
- Re-synchronisation of physical limit positions
- Cable 2.5 m white

3. Scope of delivery

- Motor 45 mm tube diameter with 2.5 m connection cable
- Operating instructions
- Adapter set, comprising tube adapter / adapter ring
- Mounting-kit, comprising safety clip / safety cotter

4. Intended use

These types of tubular motor described in these manual is intended solely for controlling sunshade systems, awnings, screens or roller blinds. These types of tubular motor cannot be used in potentially explosive area.

These types of tubular motor are designed for using in a single sunshade system.

5. Technical data

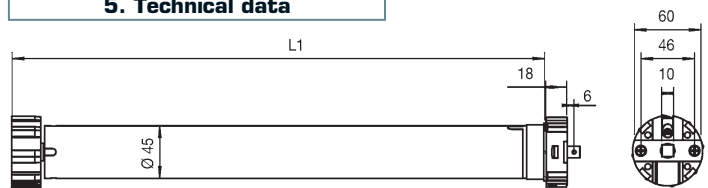

Article	VL-ME-WISO-230-45/	10Nm VRS	20Nm VRS
	Art.-no.:	01066231	01066241
Torque (nominal)	Nm	10	20
Output speed	rpm	15	15
Tractive power	kg	20	40
Supply voltage	VAC	230	230
Frequency	Hz	50	50
Rated power	W	126	165
Rated current	A	0.55	0.72
Running time	Min.	4	4
Protection degree	IP	44	44
Radio frequency	MHz	868	868
Length L1	mm	461	461

6. Installation, assembly, disassembly

6.1 Wiring diagram

ATTENTION! Parallel control of more than one conventional drive motor can only be implemented by means of isolating relays.

Wire colours of motor connection cables:
 – green/yellow: ground conductor/PE – brown: phase turning direction 1
 – blue: neutral conductor/N – black: phase turning direction 2

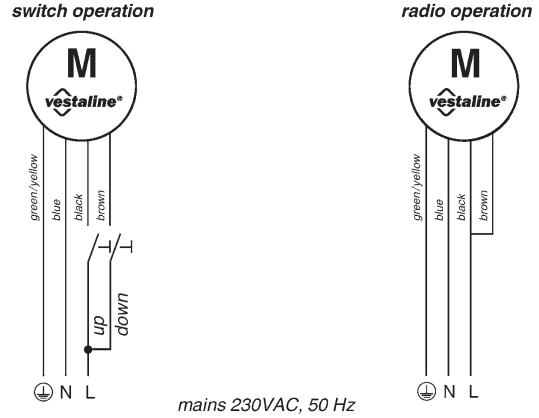

6.2 Assembly

The connection cable should be installed in a conduit to the junction box, in compliance with the local building and electrical regulations. Avoid any contact between moving objects and connection cables by routing the cables according fig.1.
 Move the roller shutter or screen completely down before disconnecting the tube connectors.
 Dissassembly of tubular shaft.
 Place the mounting bracket to the desired position. Assembly of the motor can be performed on both sides.
 Slide the Adapter ring (A) on the adjustment ring (B). Be aware of the correct installation of the notch with the Adapter (D). (See figure. 2)
 Place the tube adapter (E) on to the motor axle (F) and secure it with the safety clip (G) that comes within the mounting-kit.
 Be careful when sliding the tubular motor completely into the tubular shaft, until the adapter ring is covered into the tubular shaft. (Fig. 3). Under no circumstances external force should be applied to the motor in any way.
 Place the motor head and tubular shaft into the mounting bracket and check for proper fit. Secure the square pin of the motor head with the safety cotter that comes with the mounting-kit. Make sure to install the motor in a position that the adjustment screws are accessible from the outside.

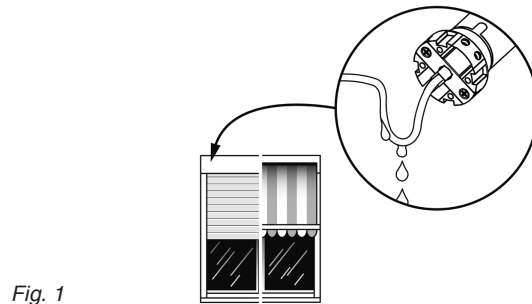

Fig. 1

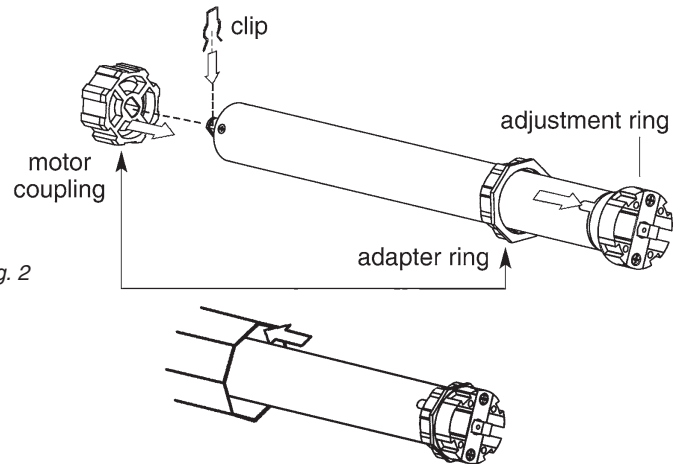

Fig. 2

6.3 Disassembly

The workflow is the same as in the section “6.2 „Installation” (see above) but in reverse order.
 The setup of limit positions can be skipped.

Fig 3

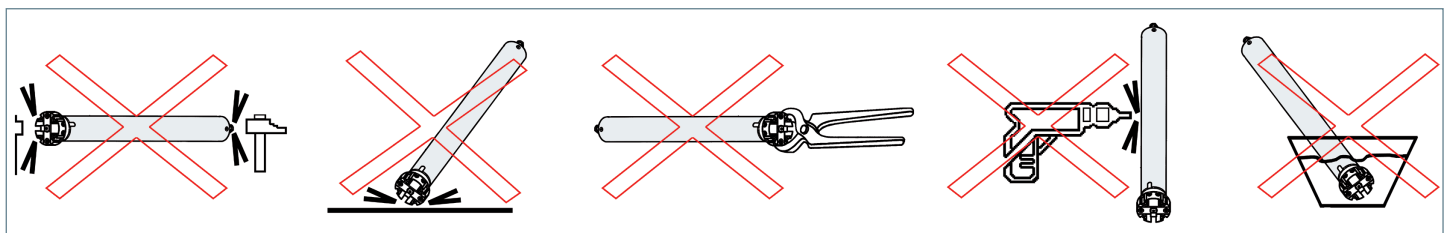

Fig. 4.1

Fig. 4.2

Fig. 4.3

Fig. 4.4

Fig. 4.5

Electronic limit position setting with Installation tool

How to connect to an Installation tool (VL-Progset-ME/SMI-230 / Art.-no.: 54185775).



IMPORTANT!

- Switch off the power supply. Connect the wire of the motor to the terminal clamps of the installation tool.
- It is important that the motor-wire-colors correspond with the installation-tool-wire-colors, otherwise the motor turning direction could be set incorrect. Switch on the power supply.
- The installation tool is not suitable for continuous operation and has only been used for set the limit position.

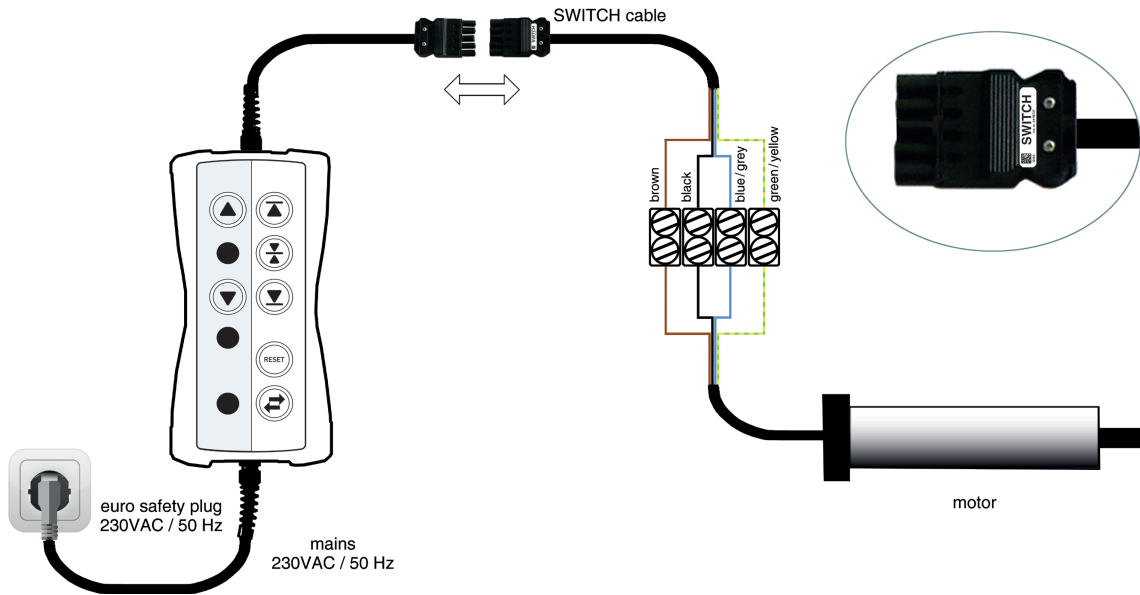

Description of installation tool LL-Progset-ME24/SMI24

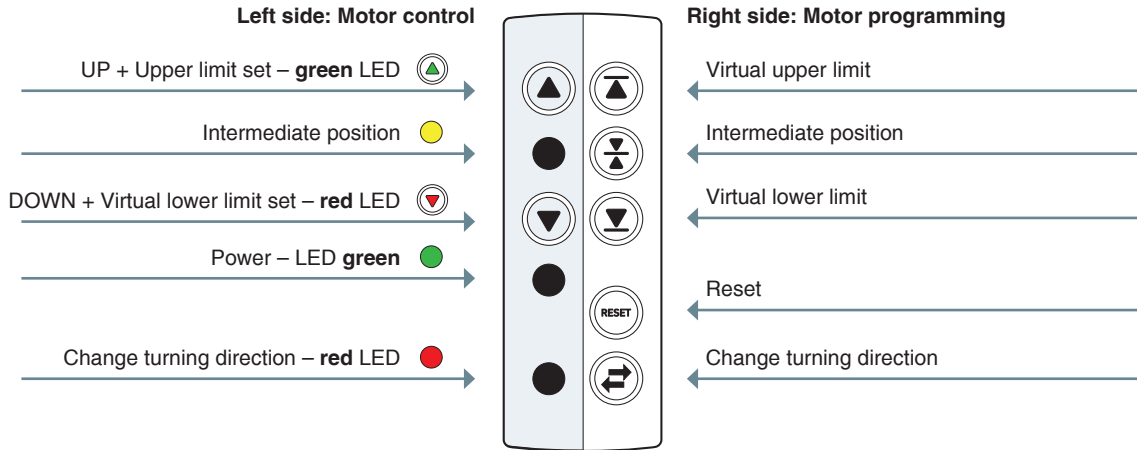

Motor control		Motor programming		
<p>Button Control motor in UP direction Hold down the button to move the motor in UP direction.</p>				
<p>LED green LED – upper limit position:</p> <p><i>OFF</i> when no “Upper limit” is set.</p> <p><i>Blinking</i> when “Upper limit” or „Reset“ programming is in progress.</p> <p><i>Lit solid</i> when “Upper limit” programming sequence has completed.</p>	 green		Button	Set “Virtual upper limit position”.
<p>LED yellow LED – Intermediate position:</p> <p><i>OFF</i> when no “Intermediate position” is set.</p> <p><i>Blinking</i> when “Intermediate position” programming is in progress.</p> <p><i>Lit solid</i> when “Intermediate position” programming sequence has been completed.</p>	 yellow		Button	Set “Intermediate position”.
<p>Button Control motor in DOWN direction Hold down the button to move the motor in DOWN direction.</p>				
<p>LED red LED – Virtual lower limit position:</p> <p><i>OFF</i> when no “Virtual lower limit” is set.</p> <p><i>Blinking</i> when “Virtual lower limit” or „Reset“ programming is in progress.</p> <p><i>Lit solid</i> when “Virtual lower limit” programming sequence has completed.</p>	 red		Button	Set “Virtual lower limit position”.
<p>LED green LED – Power:</p> <p><i>OFF</i> when powerless (it is safe to connect a motor to the Installation Tool).</p> <p><i>Lit solid</i> when attached to mains 230VAC.</p>	 green		Button	Reset
<p>LED red LED – Change turning direction:</p> <p><i>OFF</i> when no “Change turning direction” is used.</p> <p><i>Blinking</i> when “Change motor turning direction” programming sequence is in progress.</p> <p><i>Lit solid</i> when “Change motor turning direction” programming sequence has completed.</p>	 red		Button	Change motor turning direction.

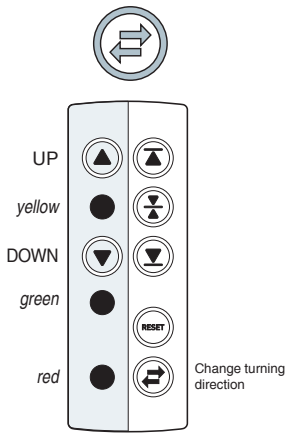

Changing motor turning direction

- Hold down the button ▲ or ▼ to check the motor turning direction.
- When the motor reacts in opposite direction (when motor goes down when you press up and vice-versa), you need to change the motor direction. Motor direction can only be changed during installation phase, when no limit positions are set.
- Press the button ↻ shortly.
- The red LED ● starts blinking as long as the change motor turning direction process is in progress.
- The red LED ● lit solid if the process is finished.

Electronic limit position setting combination

ULP = is an abbreviation for Upper Limit Position.
 LLP = is an abbreviation for Lower Limit Position.
 Following combinations virtual / physical limit position settings are possible:

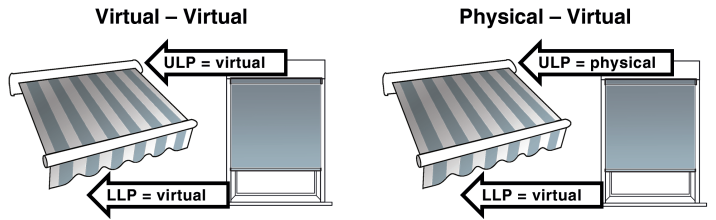

Setting electronic limit position



ATTENTION!

- The motor starts to move with a short delay time during installation-phase, when no limit positions are set.
- **Conditions to use the physical (automatic) limit position settings:**
 The upper limit stop has to be installed.

Virtual - Virtual

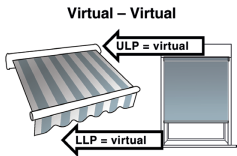

Start with upper limit position setting

- Hold down the button ▲ to move the motor in the requested upper limit position. For precise moving of the motor briefly press the button ▲, press again and hold.
- Press the button ↻ shortly.
- The green LED of button ▲ starts blinking as long as the limit setting process is in progress.
- The green LED lit solid if the process is finished.
- Hold down the button ▼ to move the motor in the requested lower limit position. For precise moving of the motor briefly press the button ▼, press again and hold.
- Press the button ↻ shortly.
- The red LED of button ▼ starts blinking as long as the limit setting process is in progress.
- The red LED of button ▼ lit solid if the process is finished.
- The motor will give a feedback (short UP/DOWN movement) to confirm that the installation procedure has ended.

Start with lower limit position setting

- Hold down the button ▼ to move the motor in the requested lower limit position. For precise moving of the motor briefly press the button ▼, press again and hold.
- Press the button ↻ shortly.
- The red LED of button ▼ starts blinking as long as the limit setting process is in progress.
- The red LED lit solid if the process is finished.
- Hold down the button ▲ to move the motor in the requested upper limit position. For precise moving of the motor briefly press the button ▲, press again and hold.
- Press the button ↻ shortly.
- The green LED of button ▲ starts blinking as long as the limit setting process is in progress.
- The green LED of button ▲ lit solid if the process is finished.
- The motor will give a feedback (short UP/DOWN movement) to confirm that the installation procedure has ended.

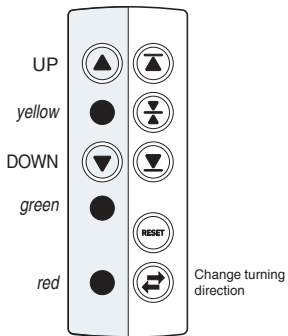

Physical – Virtual

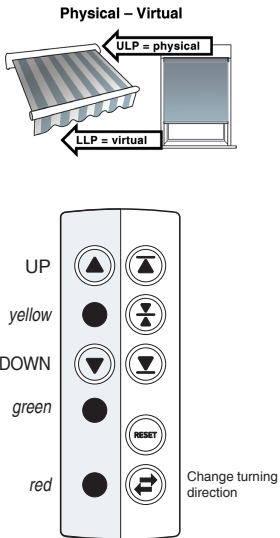

Start with upper limit position setting

- Hold down the button ▲ till motor stops automatically due to obstacle detection. Upper physical limit position is now set.
- Hold down the button ▼ to move the motor in the requested lower limit position. For precise moving of the motor briefly press the button ▼, press again and hold.
- Press the button ▾ shortly.
- The red LED of button ▼ starts blinking as long as the limit setting process is in progress.
- The red LED of button ▼ lit solid if the process is finished.
- The motor needs the following complete movement to memorize the limit positions. Hold down the button ▲ to move the motor in the requested direction.
- The motor will give a feedback (short UP/DOWN movement) to confirm that the installation procedure has ended.

Start with lower limit position setting

- Hold down the button ▼ to move the motor in the requested lower limit position. For precise moving of the motor briefly press the button ▼, press again and hold.
- Press the button ▾ shortly.
- The red LED of button ▼ starts blinking as long as the limit setting process is in progress.
- The red LED lit solid if the process is finished.
- Hold down the button ▲ till motor stops automatically due to obstacle detection. Upper physical limit position is now set.
- The motor needs the following complete movements (figure 3) to memorize the limit position. Hold down the button ▼ or ▲ to move the motor in the requested direction.
- The motor will give a feedback (short UP/DOWN movement) to confirm that the installation procedure has ended.

Save intermediate position

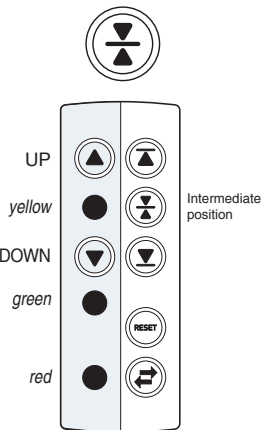

- The intermediate position can be saved only after the lower and upper limit positions have been saved finally.
- Hold down the button ▼ or ▲ to move the motor in the requested position.
- Press button for "Intermediate position" to store the position. The yellow LED flashes while the intermediate position is being stored.
- The yellow LED lit solid if the process is finished. The motor will give a feedback (short DOWN/UP movement) to confirm that the installation procedure has ended.
- The stored intermediate position can be changed/overwritten at any time.

Motor – Reset

1. Clear – LED status

Clear the installation tool LED-status. Keep the RESET button ⊖ pressed till the LEDs turn off.

2. Delete the limit position settings of the motor

Press the RESET button ⊖, till the LEDs start blinking. The LEDs keep blinking as long as the motor reset process is in progress. When the reset process is finished, the LEDs turn off, the motor limit positions have been cleared, and can be set again. The motor will shortly move during the reset sequence.

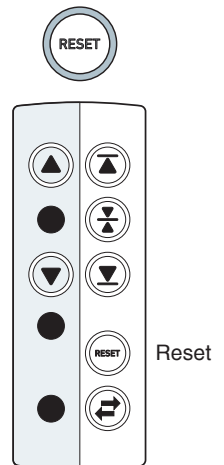

NOTE!

Tubular motor might be switched off before reaching the limit position: Extraordinary large increases of load (anti-block-function) – obstacles, sunshade system keeps jamming, tubular motor is overloaded.

Remedy action:

- Removing the obstacle.
- Check the mechanical parts of the sunshade system.
- Use the correct tubular motor (rated torque – tractive power) according to the specification of the sunshade system.

6.4 Settings/Functions of the motors in radio operation VRS = Vestamatic Radio System

The motor can be controlled with various VRS radio transmitters. Subsequently, these are described depending on the radio transmitter type. A maximum of 16 transmitters per motor can be programmed.

Description of radio remote control VRS

Function + Programming Transmitter

Radio Remote Control VRS

A. LED indication of selected channel of the transmitter.

To change channel:

Press and hold "STOP" for 3–6 s (LEDs start to blink), then use the ON/UP ▲ or OFF/DOWN ▼ button to select wanted channel and confirm by pressing "STOP".

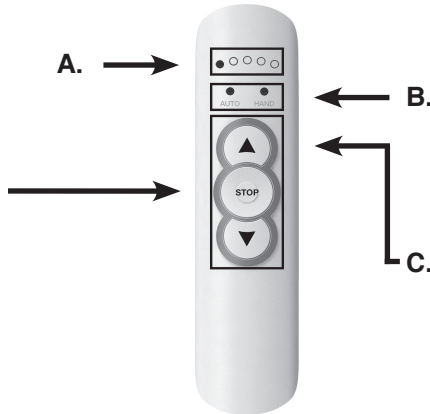

B. Radio remote control 5K:

Switching from AUTO to HAND mode (receiver-dependent). Press and hold the "STOP" button (middle button) for 6 seconds, the LEDs AUTO or HAND will start lighting). Release the STOP button and use the UP button to select wanted mode and confirm by pressing "STOP".

Radio remote control 10K:

Left LED indication channel 1–5
Right LED indication channel 6–10

C. Manual control buttons.

- Channel 1–10 = Motor / Shade
- Button ON/UP = ▲
- Button STOP
- Button OFF/DOWN = ▼

Description of radio wall transmitter VRS Switch

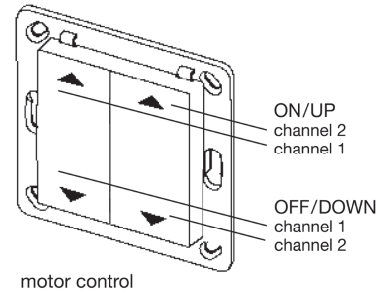
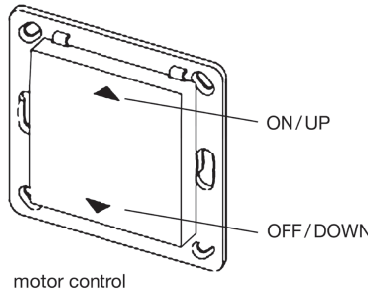

Programming for initial operation respectively after RESET

Radio remote control VRS Transmitter

Radio wall transmitter VRS Switch



PROG. button at the back side

1. Switch on the power supply of the motor. Programming mode is now active for 60 sec.
2. Press PROG. button at the back side of the remote control.
3. LEDs on the front side of the remote control start flashing.
4. Press and release the STOP button shortly. The motor will give a feedback (short UP/DOWN movement). Programming was successful. The flashing of the LEDs on the front side of the remote control stops after about 15 sec., then the motor can be driven.
5. To drive the motor in UP or DOWN direction, please press the respective button. Motor moves with a delay, since no final positions are set.



1. Switch on the power supply of the motor. Programming mode is now active for 60 sec.
2. Press PROG. button at the back side of the remote control.
3. LED starts flashing.
4. Press ON/UP or OFF/DOWN button of the channel for programming shortly.
5. The motor will give a feedback (short UP/DOWN movement) to confirm that the installation procedure has ended.
6. To drive the motor in UP or DOWN direction, please press the respective button. Motor moves with a delay, since no final positions are set.

Changing motor turning direction

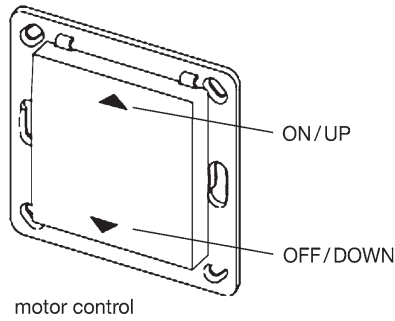

motor control

- Hold down the button or to check the motor turning direction.
- When the motor reacts in opposite direction (when motor goes down when you press UP and vice-versa), you need to change the motor direction. Motor direction can only be changed during installation phase, when no limit positions are set.
- Shortly press the following combination of buttons (within 10 seconds):
- The motor will give a short feedback if the process is finished.

Setting electronic limit position

Electronic limit position setting combination



ATTENTION!
The motor starts to move with a short delay time during installation phase, when no limit positions are set.

ULP = is an abbreviation for Upper Limit Position.

LLP = is an abbreviation for Lower Limit Position.

Following combinations virtual/physical limit position settings are possible:

Physical - Virtual

Physical - Virtual

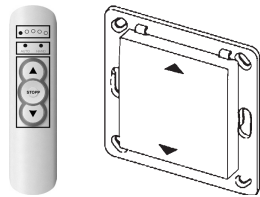
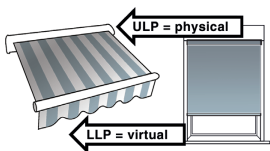

Both upper and lower limit position are virtual.

Start with upper limit position setting

- Hold down the button till motor stops automatically due to obstacle detection. Upper physical limit position is now set.
- Hold down the button to move the motor in the requested lower limit position. For precise moving of the motor briefly press the button , press again and hold.
- Press the button shortly.
- The red LED of the button starts blinking as long as the limit setting process is in progress.
- The red LED of the button lit solid if the process is finished.
- The motor needs the following complete movement to memorize the limit positions. Hold down the button to move the motor in the requested direction.
- The motor will give a feedback (short UP/DOWN movement) to confirm that the installation procedure has ended.

Start with lower limit position setting

- Hold down the button to move the motor in the requested lower limit position. For precise moving of the motor briefly press the button , press again and hold.
- Press the button shortly.
- The red LED of the button starts blinking as long as the limit setting process is in progress.
- The red LED of the button lit solid if the process is finished.
- Hold down the button till motor stops automatically due to obstacle detection. Upper physical limit position is now set.
- The motor needs the following complete movement to memorize the limit positions. Hold down the button to move the motor downwards about 20 cm. Then hold down the button UP till motor stops automatically.
- The motor will give a feedback (short UP/DOWN movement) to confirm that the installation procedure has ended.

Virtual - Virtual

Virtual - Virtual

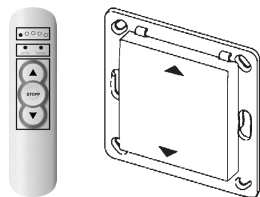
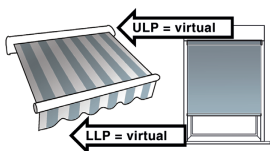

Both upper and lower limit position are virtual.

Start with upper limit position setting

- Hold down the button to move the motor in the requested upper limit position. For precise moving of the motor briefly press the button , press again and hold.
- Press the button shortly.
- The green LED of the button starts blinking as long as the limit setting process is in progress.
- The green LED of the button lit solid if the process is finished.
- Hold down the button to move the motor in the requested lower limit position. For precise moving of the motor briefly press the button , press again and hold.
- Press the button shortly.
- The red LED of the button starts blinking as long as the limit setting process is in progress.
- The red LED of the button lit solid if the process is finished.
- The motor will give a feedback (long UP/DOWN movement) to confirm that the installation procedure has ended.

Start with lower limit position setting

- Hold down the button to move the motor in the requested lower limit position. For precise moving of the motor briefly press the button , press again and hold.
- Press the button shortly.
- The red LED of the button starts blinking as long as the limit setting process is in progress.
- The red LED of the button lit solid if the process is finished.
- Hold down the button to move the motor in the requested upper limit position. For precise moving of the motor briefly press the button , press again and hold.
- Press the button shortly.
- The green LED of the button starts blinking as long as the limit setting process is in progress.
- The green LED of the button lit solid if the process is finished.
- The motor will give a feedback (long UP/DOWN movement) to confirm that the installation procedure has ended.

**Adjusting already set limit positions of the motor
Change the electronic limit positions**



IMPORTANT!
The motor starts to move with a short delay time during installation phase, when no limit positions are set.



PROG. button at the back side



NOTE:
Adjusting only with radio remote control, not available with wall-mounted transmitter.

Press the PROG. button twice (see figure left) on the back side of the radio remote control until the following LEDs flash.

Start with lower limit position setting

- Hold down the button to move the motor in the requested *lower* limit position.
For precise moving of the motor briefly press the button , press again and hold.
- Press the following button sequence (within 10 seconds): 5 × short .
- The motor will give a short feedback if the process is finished.
- Hold down the button to move the motor in the requested *upper* limit position.
For precise moving of the motor briefly press the button , press again and hold.
- Press the following button sequence (within 10 seconds): 5 × short .
- The motor will give a short feedback if the process is finished.
- The installation procedure is finished and the limit position settings are saved.
- The blinking of the LEDs on the front side of the remote control disappears after about 15 seconds, then the motor can be driven.

Save intermediate position



NOTE:
Save intermediate position (only with radio remote control, not available with wall-mounted transmitter).



- The intermediate position can be saved only after the lower and upper limit positions have been saved finally.
- Hold down the button or to move the motor in the requested position.
- When the desired position is reached, press the following button sequence (within 10 seconds): 5 × shortly the **STOP** button.
- The motor will give a feedback (short UP/DOWN movement) to confirm that the installation procedure has ended.

- Once the intermediate position is stored, the motor reacts according to button stroke length.
 - Press the UP or DOWN button = Intermediate position.
 - Press the button UP or DOWN for longer than 1 second = run over the intermediate position.
- If a VRS lux sensor is programmed, the motor moves into the intermediate position, according to the lux value of the sensor.
- The stored intermediate position can be changed/overwritten at any time.

Deleting the intermediate position:

- Driving the motor in the lower limit position.
- When the limited position is reached, press the following button sequence (within 10 seconds): 5 × briefly the **STOP** button.
- The motor will give a short feedback if the process is finished.

Motor - RESET

Delete the limit position settings of the motor and all programmed radio transmitter

■ **By means of the programmed radio remote control**



PROG. button at the back side



1. Press the **PROG.** button (see figure left) on the back side of the radio remote control several times until the following LEDs flash. Then press the **STOP** button.
2. The motor briefly performs ON/UP and OFF/DOWN commands. The blinking of the LEDs on the front side of the remote control disappears after about 15 seconds, then the motor can be driven.

■ **By means of the programmed radio wall transmitter**



LED
PROG. button

1. Press the **PROG.** button for at least 10 seconds (see figure) on the back side of the radio wall transmitter, the red LED flashing fast.
Now press the ON/UP or OFF/DOWN button for at least 10 seconds, before you release the button.
2. The motor briefly performs ON/UP and OFF/DOWN commands.

After the motor RESET, the programming mode is automatically active for 60 seconds. The motor starts to move with a short delay time during installation phase, when no limit positions are set.

Programming of additional remote controls

Option 1

Switch off the power supply of the motor for minimum 3 seconds. Switch on the power supply of the motor again. Now the programming mode is active for 60 seconds.

- **Radio remote control VRS Transmitter** – as described above.
- **Radio wall transmitter VRS Switch** – as described above.
- **VRS Luxsensor S:**

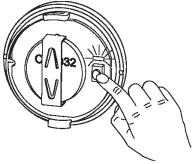

- Press the **PROG.** button of the lux sensor (s. figure left) shortly.
- Red LED next to the button flashes.
- After successful programming the motor gives a short feedback.

■ **VRS WISO Crystal Control**

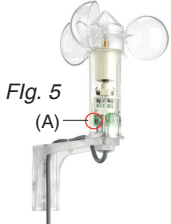

Fig. 5
(A) Hold magnet close to PROG POINT at the sensor.

- Hold magnet close to PROG POINT, the yellow LED will be lit up.
- After successful programming the motor gives a short feedback.

i **NOTE:**

A maximum of one lux sensor or VRS WISO Crystal Control can be programmed. Overwriting by another sensor is done by option 2.

Option 2

Programming of additional radio transmitter by means of a programmed radio transmitter.

- Select the corresponding channel with the programmed radio transmitter.
- Press the **PROG.** and then the **STOP** button (radio remote control) resp. ON/UP or OFF/DOWN button (wall-mounted radio transmitter).
- The motor is now for **10 sec. in programming mode.** The motor performs a short ON/OFF and UP/DOWN movement command.

■ **Programming the radio remote control VRS transmitter:**
Press the PROG. and then the STOP button.

■ **Programming the radio wall transmitter VRS Switch:**
Press the PROG. and then the ON/UP- or OFF/DOWN button.

■ **Programming the VRS Luxsensor S:**
Press the PROG. button of the lux sensor (s. figure left) shortly.

■ **Programming WISO VRS Sensor:**
Hold magnet close to PROG POINT, the yellow LED will be lit up.

Successful programming

The motor briefly performs ON/UP and OFF/DOWN commands.

i **NOTE!**

See WISO VRS manual how to set sun and wind threshold settings. During the installation phase of the motor (when limit position settings are not confirmed yet by the motor), the WISO VRS commands will be suppressed.

When the motor is blocked by the WISO VRS (due to wind alarm or communication time-out), the motor cannot be operated by remote control, but will give a feedback (short DOWN/ UP movement) to show the user that it is still alive and working.

When no confirmation is given by the motor, possible causes:

- Motor did not receive the "Teach" command correctly, or remote control receiver list is full.
- Maximum of 16 Motors can be taught to a motor.
- A other sensor is already "linked" with the motor. A maximum of one lux sensor or VRS WISO Crystal Control can be programmed.

Deleting a programmed radio remote control

■ **By means of the programmed radio remote control**



PROG. button at the back side

1. Press the **PROG.** button (see figure left) on the back side of the radio remote control several times until the following LEDs flash (Fig. B). Then press the STOP button.
2. The motor briefly performs ON/UP and OFF/DOWN commands. Delete mode will now be enabled for 10 seconds.

■ **Deleting a radio remote control VRS Transmitter**

- Within 10 seconds, press the **STOP** button on the radio remote control to be deleted. When you release the button, the motor briefly performs two ON/UP and OFF/DOWN move commands.
- Cancellation is now effective.

■ **Deleting a wall-mounted radio transmitter VRS Switch**

- Hold within 10 seconds, the **ON/UP or OFF/DOWN** button on the radio wall transmitter to be deleted for at least 5 seconds, before you release the button again. When you release the button, the motor briefly performs two ON/UP and OFF/DOWN move commands.
- Cancellation is now effective.

■ **By means of the programmed radio wall transmitter**

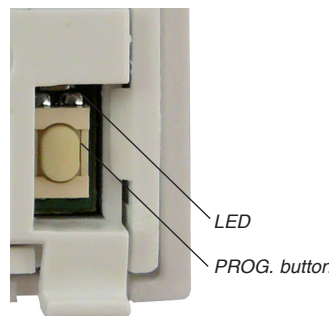

1. Press the **PROG.** button for at least 10 seconds (see figure) on the back side of the radio wall transmitter once, the red LED flashes. Now press the ON/UP or OFF/DOWN button for at least 10 seconds, before you release the button.
2. The motor briefly performs ON/UP and OFF/DOWN commands. Delete mode will now be enabled for 10 seconds.

Deleting a VRS Luxsensor S

- Within 10 seconds, press the **PROG.** button on the VRS Luxsensor S to be deleted. The LED flashes once, the motor briefly performs two ON/UP and OFF/DOWN move commands.
- Cancellation is now effective.

■ **Deleting a VRS WISO Crystal Control**

- Hold magnet close to PROG POINT, the yellow LED will be lit up. See Fig. 5 as described in (A).
- Motor will give a short confirmation (2 x short UP/ DOWN movement).
- Cancellation is now effective.

7. Troubleshooting

Problem	Possible cause	Solution
■ Motor is not responding.	1. No mains voltage. 2. Connection error. 3. Cutoff by internal temperature fuse.	1. Check mains voltage. 2. Check connections (see wiring diagram). 3. Allow the motor to cool down for 20 min.
■ Motor starts slowly or makes too much noise.	1. Connection error. 2. Installation error or undersized motor selected.	1. Check connections. 2. Check installation and motor load.
■ Motor rotation direction is wrong.	Motor connection cables are reversed.	Disconnect the supply line from the power, and swap the black and brown conductors of the motor cable at the controller.
■ Motor stops while moving up or downwards.	1. Preset endpoint reached. 2. Cutoff by internal temperature fuse.	1. Set the end limits again, according to the instructions. 2. Allow the motor to cool down for 20 min.
■ Motor stops while moving upwards.	Iced shutters or obstacle in running rail.	Remove icing or obstacle. Release the shutters by steering the motor in downward direction.

8. Warranty

Principally, the General Terms and Conditions of the manufacturer, Vestamatic GmbH apply. The terms and conditions are part of the sales documents and handed over to the operator upon delivery. Liability claims for personal or material damages are excluded when they can be attributed to one or more of the following causes:

- Unintended use of the product.
- Opening of the product by the customer.
- Improper installation, commissioning, or operation of the product.
- Non-compliance with the specifications.
- Non-observance of the safety provisions and instructions of the Operating Instructions.
- Operation of the product with improperly installed connections, defective safety devices or improperly installed safeguards.
- Modifications to the product.

9. Maintenance

The motor is maintenance-free.

10. Disposal of waste

The disposal of electrical equipment and batteries in household waste is strictly forbidden.



The symbol (dustbin crossed out, in line with WEEE Appendix IV) indicates separate collection of electrical and electronic products in EU countries. Do not dispose of the device or battery in your household waste. Ask your town or local council about the return and collection systems available in your area to dispose of this product.

11. Support/Contact

If you have any problems with our product or receive a defective device, please contact the following address:

Vestamatic GmbH
 Dohrweg 27
 41066 Mönchengladbach
 Germany
 info@vestamatic.com
 Phone: +49 2161 / 29 408-0



EG-Konformitätserklärung *EC-Declaration of conformity*

Hersteller: **Vestamatic GmbH**
Manufacturer:
Anschrift: **Dohrweg 27**
Address: **D-41066 Mönchengladbach**

Produktbezeichnung: **VL-MM-230-45/...**
Product designation:
Artikel-Nummer: **01066043; 01066042; 01066061**
Article number:

Das bezeichnete Produkt ist konform mit den Anforderungen der folgenden Richtlinie(n):
The designated product is in conformity with the requirements of the following directive(s):

EMC Directive on Electromagnetic Compatibility (EMC)	2004/108/EC
Machinery Directive	2006/42/EC

Die Konformität wurde überprüft anhand der harmonisierten EN-Norm(en):
The conformity was checked in accordance with the following harmonised EN standard(s):

EN 55014-1:2006+A1:2009+A2:2011
EN 55014-2:1997+A1:2001+A2:2008
EN 61000-3-3:2013
EN 61000-3-2:2014

EN 60335-1:2012
EN 60335-2-97:2010
EN 62233:2008

Jahr in dem CE-kennzeichnung angebracht wurde:
Year of affixing CE marking:

2014

Mönchengladbach, 22. September 2015

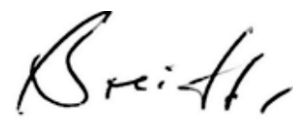

Thorsten Breithor
(Geschäftsführer / General Manager)

