



INSTALLATION AND OPERATING INSTRUCTIONS LL-ME-24-24/0,9NM RB

LL-ME-24-24/0,9NM RB



This manual is suitable for the following products:

- LL-ME-24-24/0,9Nm RB (01010200)

Dokumentnummer: 8350010 A01

Loveline motor for the
control of Roller blinds
und Screens.

Read the manual before starting the installation.
Failure to follow the instructions may result in defects that are not
covered by the warranty. Errors and technical changes excepted.



Manual EN



Manual NL

CONTENT

■ Safety instructions	2	■ Installationstool LL-Progset-ME24/SMI24	7
■ Technical data	3	■ Maintenance / Warranty	12
■ Mounting / Installation	4		
■ Wiring diagram	6		

SAFETY INSTRUCTIONS

GENERAL INFORMATION

These safety instructions are an integral part of the product and must be read and fully understood before installation, electrical connection, commissioning and operation.

- The device may only be used for its intended purpose as described in this documentation.
- Installation, electrical connection and commissioning may only be carried out by a qualified electrician.
- The motor must be checked for visible damage before installation. Damaged devices must not be put into operation.
- Any modification or alteration of the device is prohibited and will void all warranty and liability claims.
- Do not allow children to play with fixed control devices. Keep remote controls out of reach of children.
- The system must be checked regularly for imbalance, wear, or damaged cables and components.

SAFETY WARNINGS



ELECTRICAL HAZARDS

DANGER – Risk of fatal electric shock.
Disconnect the mains voltage completely before installation and before working on the device.



HAZARDS DUE TO MOVEMENT OF ROLLER BLINDS AND SCREENS |

WARNING –
Risk of injury due to crushing, shear points or uncontrolled movements.



NOTE

The complete safety instructions can be found at: www.vestamatic.com/safety



SCAN ME

SUPPORT/CONTACT

Vestamatic International GmbH
Am Tannenbaum 2 | 41066 Mönchengladbach
E-Mail: info@vestamatic.com

TECHNICAL DATA

SHORT DESCRIPTION

- Loveline motor for 24 VDC
- For precise control of roller shutters/screens
- In switch mode, simple operation via standard buttons
- Motor speed reduced at start/stop
- Parallel operation of up to 16 motors (switch mode)
- Synchronous movement of shading systems
- Upper and lower limit positions electronically programmable
- Intermediate position memory
- Easy limit adjustment using the “LL-Progset-ME24/SMI-24” (Art. No.: 54185735)
- Obstacle detection / braking function

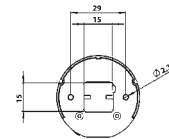
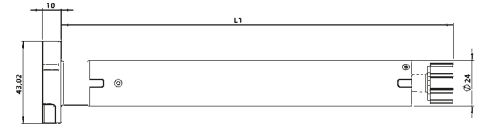

PARAMETER	VALUE
Supply voltage range:	22 – 28 VDC
Nominal supply voltage:	24 VDC
Rated Power (idle):	0,2 W ¹⁾
Rated Power (nominal):	6 W ¹⁾
Rated Power (maximum):	12 W ¹⁾
Rated Torque:	65 Ncm
Maximum Torque:	90 Ncm ²⁾
Maximum Running time:	10 Min. at ambient temperature of +25 °C
Output speed:	5 – 30 min ⁻¹
Operating temperature	-10 °C to +85 °C

TECHNISCHE DATEN

PARAMETER	VALUE
Protection degree	20
Connection terminal	JST
Application	177mm
Conformity	CE

¹⁾ At recommended supply voltage

²⁾ At a speed of 23 min⁻¹

MOUNTING / INSTALLATION

The motor is designed for installation in various system shafts. The corresponding adapter sets can be found in the accessories range (not included in delivery).

A. Adapter sets (roller shutters/screens):

A1 = drive

A2 = idler

A3 = bearing block

For correct installation, please refer to the mounting instructions. You can freely choose between the above-mentioned shaft adapter types.

The motor is equipped with a JST PHR-4 terminal connection. The electrical connection must be carried out according to the wiring diagram (see following pages). Suitable connection cables are available in the accessories range (not included in delivery).

MOUNTING / INSTALLATION

MOUNTING OF THE ADAPTER SETS

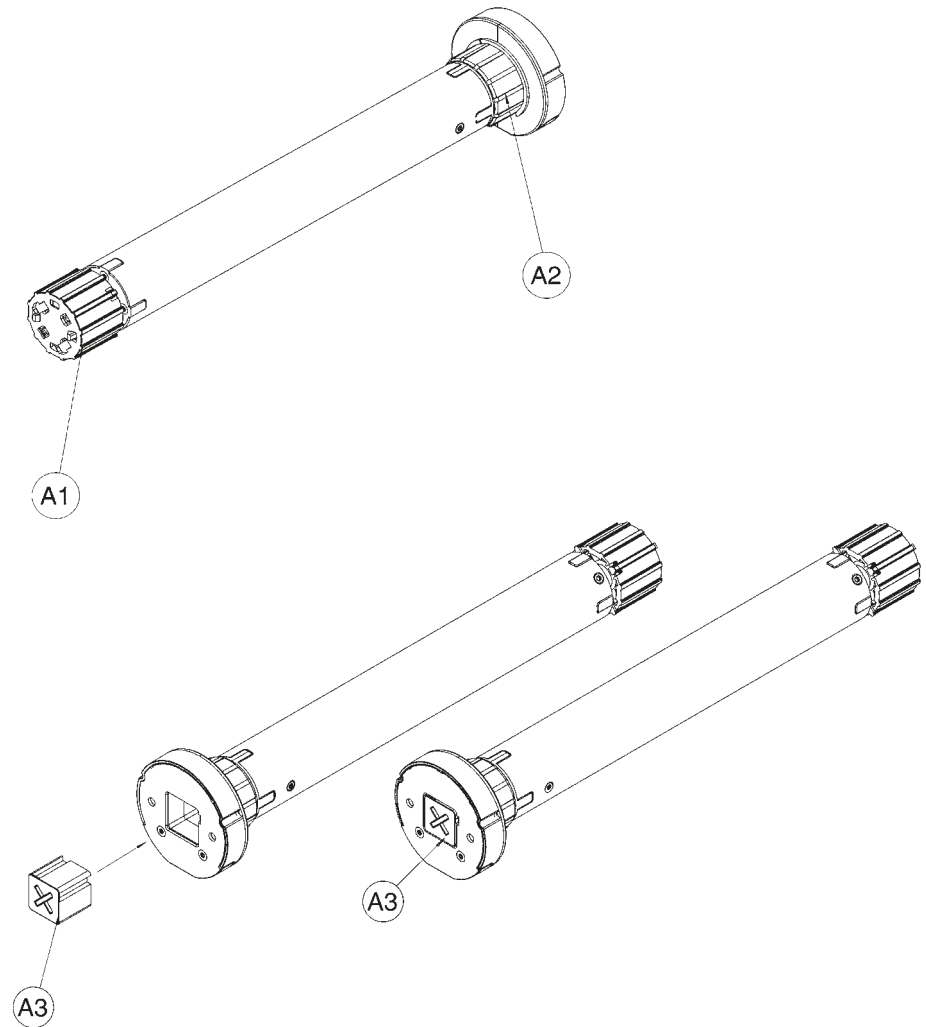

WIRING DIAGRAM

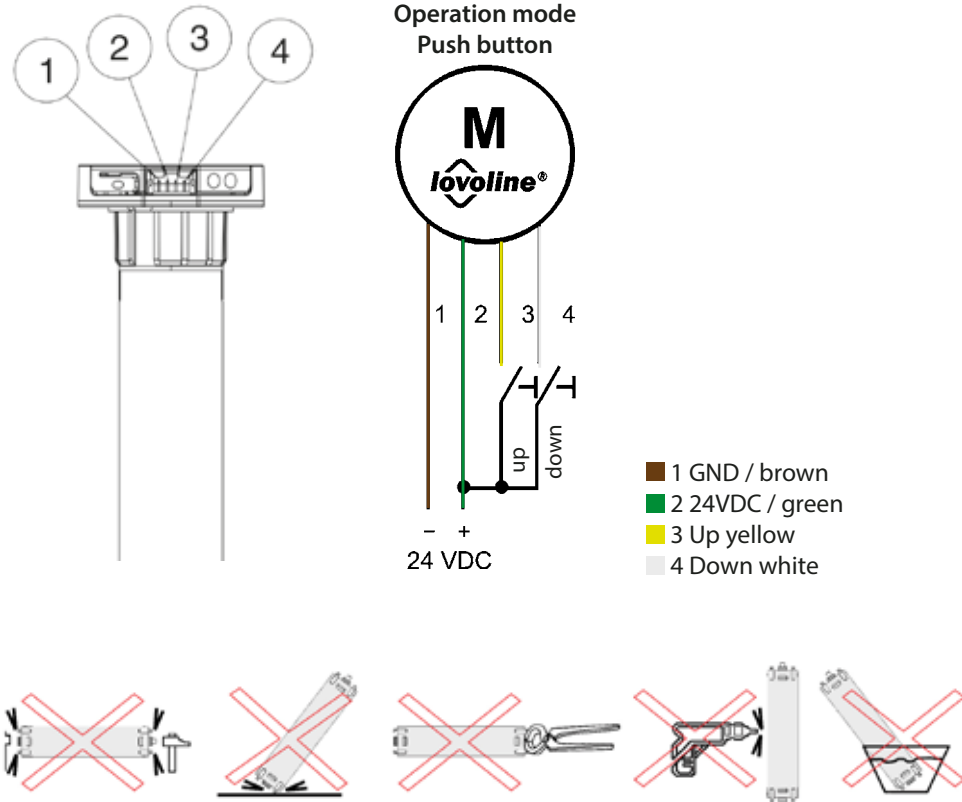

INSTALLATIONSTOOL LL-PROGSET-ME24/SMI24

ELECTRONIC LIMIT ADJUSTMENT WITH THE INSTALLATION TOOL

Connect to the installation tool (LL-Progset-ME24/SMI-24 / Art.-No.: 54185735).



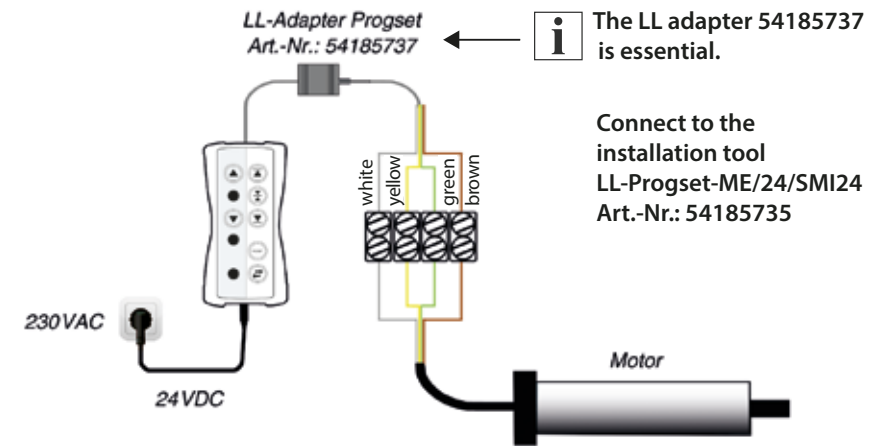



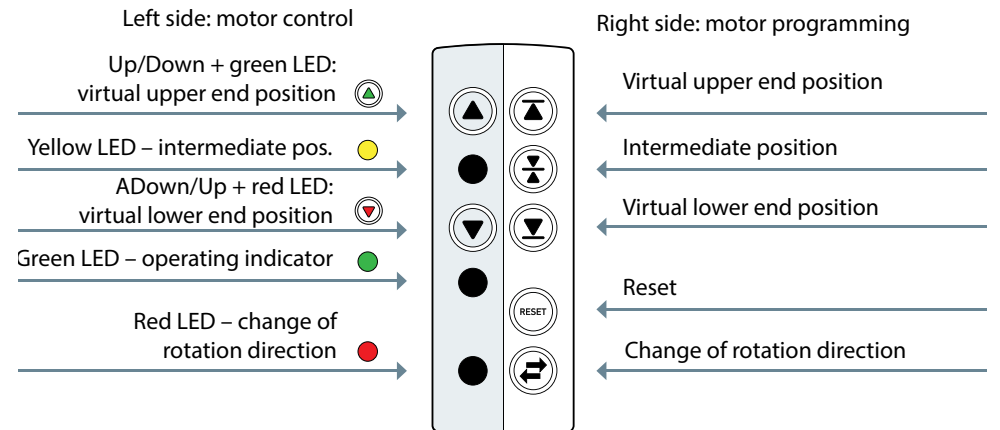



- Switch off the power supply. Connect the corresponding cable to the motor and to the installation tool.
- It is important that the colors of the motor connection cables and the installation tool match. Otherwise, the motor rotation direction may be set incorrectly. Switch on the power supply.
- The installation tool is not suitable for continuous operation and is intended solely for limit adjustment.





DESCRIPTION OF THE INSTALLATION TOOL LL-PROGSET-ME 24 / SMI 24



DESCRIPTION OF THE INSTALLATION TOOL LL-PROGSET-ME24 / SMI24

Motor control		Motor programming			
Button	For controlling the motor in the upward direction. Press and hold the button to move the motor upward.				
LED	Green LED (upper end position): OFF = no upper end position set Flashing: = saving of the upper end position or RESET is being executed lights up: = upper end position is stored	 green		Button	To save the virtual upper end position. Move in upward direction.
LED	Yellow LED (intermediate position): OFF = no intermediate position set Flashing: = saving of the intermediate position lights up: = intermediate position is stored	 yellow		Button	To save the intermediate position.
Button	For controlling the motor in the downward direction. Press and hold the button to move the motor downward.				
LED	Red LED (virtual lower end position): OFF = no virtual lower end position set Flashing: = saving of the virtual lower end position or RESET is being executed lights up: = virtual lower end position is stored	 red		Button	To save the virtual lower end position.
LED	LED – Green LED (operation indicator): OFF = no operating voltage (safe mode after connecting the motor to the installation tool) lights up: = operating voltage (230 VAC) present	 green		Button	Reset
LED	Red LED (change of rotation direction): OFF = no change of rotation direction Flashing: = change of rotation direction in progress lights up: = change of rotation direction completed	 red		Button	Execute change of rotation direction

CHANGE MOTOR ROTATION DIRECTION

Check rotation direction
Press and hold
Up  or down 



The rotation direction must be changed if the motor runs in the wrong direction (e.g. downward when pressing UP).

The rotation direction can only be changed during the installation phase, when no end positions have been set yet.

Change rotation direction
Press the Button  1x



If the power supply is connected, the red LED lights continuously. The motor gives a short feedback (rotation).

The red LED flashes during the change of rotation direction.

INSTALLATIONSTOOL LL-PROGSET-ME24/SMI24

SETTING THE ELECTRONIC LIMIT POSITIONS



NOTE

The motor runs with a short start delay during the installation phase as long as the limit positions are not fully stored.

SETTING OF THE LOWER LIMIT POSITION

- 1 Press and hold the Button Or: for precise movement: press the button 2x, then hold → Motor moves downward to the desired end position
- 2 Press the button 1x → The red LED of button flashes while the limit position is being stored → When the process is complete, the red LED lights continuously. The motor gives a short feedback (short up/down movement)

SETTING OF THE UPPER LIMIT POSITION

- 1 Press and hold the Button Or: for precise movement: press the button 2x, then hold → Motor moves upward to the desired end position
- 2 Press the Button 1x → The green LED of flashes while the limit position is being stored → When the process is complete, the green LED lights continuously. The motor gives a short feedback (short up/down movement)

THE ADJUSTMENT PROCESS IS COMPLETE AND THE END POSITIONS HAVE BEEN SAVED.

- 3 Press and hold the button or x6 Sec. = self-hold.
- 4 Opposite button or stops movements

INSTALLATIONSTOOL LL-PROGSET-ME24/SMI24

SAVE INTERMEDIATE POSITION

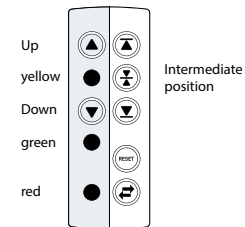

NOTE

- 1.) The intermediate position can only be stored after the upper and lower limit positions have been set.
- 2.) The stored intermediate position can be changed/overwritten at any time.

- 1 Press and hold the Button or x6 Sec. = Self hold → Press opposite button to stop movement
- 2 To save: press button 1x → The yellow LED flashes while the intermediate position is being stored → When the process is complete, the yellow LED lights continuously. The motor gives a short feedback (short up/down movement)

MOTOR RESPONSE AFTER SAVING THE INTERMEDIATE POSITION (DEPENDING ON THE DURATION OF THE BUTTON PRESS):

- 1 Press the button or 1x = Intermediate position → Press the button or for more than 1 Sec. = Overwrite the intermediate position

MOTOR-RESET

Deleting the set limit positions

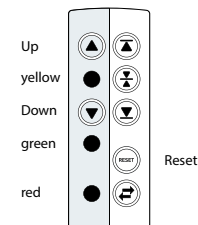

1

Press Button until the LEDs start flashing → LEDs flash during the entire reset process

The limit positions are now deleted and the motor can be set again. The motor gives a short feedback (short UP/DOWN movement).

→ When the process is complete, the LEDs turn off

MAINTENANCE / WARRANTY

In general, the manufacturer's general terms and conditions of sale and delivery apply (Vestamatic International GmbH). These terms are part of the sales documents and are handed over with delivery. Liability claims for personal injury and property damage are excluded if they are attributable to one or more of the following causes:

- Improper use of the product
- Opening of the product by the customer
- Improper installation, commissioning or operation of the product
- Non-compliance with the specified technical specifications
- Operation of the product with improperly installed connections, defective safety devices or improperly mounted safety and protective devices
- Structural modifications to the product

Maintenance: The product is maintenance-free.