



INSTALLATION AND OPERATING INSTRUCTIONS TOUCH CENTRE XL 4C WIRED

TOUCH CENTRE XL 4C WIRED



This manual is suitable for the following products:

- Touch Centre XL 4C Wired (01080212)

Documentnumber: 84500501 K1

Central controls for sun
protection systems.

Read the manual before starting the installation.
Failure to follow the instructions may result in defects that are not
covered by the warranty. Errors and technical changes excepted.



CONTENT

■ Safety instructions	2
■ Technical data	3
■ Installation / Wiring diagram	4
■ Mounting / Connection	11
■ Maintenance / Warranty	12

SAFETY INSTRUCTIONS

GENERAL SAFETY INFORMATION

These safety instructions are an integral part of the product and must be read and fully understood before installation, electrical connection, commissioning and operation.

- The Touch Centre XL 4C Wired is a central control unit for shading systems with up to four channels.
- The control unit is intended for operating shading systems such as awnings, venetian blinds or roller shutters in combination with suitable sensors and decentralised control units.
- Installation, electrical connection and commissioning may only be carried out by a qualified electrician.
- The device must be inspected for visible damage before installation. Damaged devices must not be put into operation.
- Any modification or alteration of the device is prohibited and will void all warranty and liability claims.
- The operator must ensure that these safety instructions are made available to all subsequent users.

SAFETY WARNINGS



ELECTRICAL HAZARDS

DANGER – Risk of fatal electric shock.

Disconnect the mains voltage completely before installation and before working on the device.



HAZARDS FROM MOVING SUN SHADING SYSTEMS | WARNING –

Risk of injury due to crushing, shear points or uncontrolled movements.



NOTE

The complete safety instructions can be found at: www.vestamatic.com/safety



SUPPORT/CONTACT

Vestamatic International GmbH
 Am Tannenbaum 2 | 41066 Mönchengladbach
 E-Mail: info@vestamatic.com

TECHNICAL DATA

SHORT DESCRIPTION

- Color touch display with intuitively operable symbols
- 4-channel control system for individual control of shading systems of all types
- Simplified learning and parameterization through automatic sensor detection and help function
- Potential-free group outputs for controlling central control systems
- Connection options for: 2 × wind sensors, 8 × lux sensors, 1 × rain sensor, 2 × temperature sensors, 1 × radio receiver and radio hand-held transmitter Controlbox
- Display box with integrated temperature sensor
- Individually programmable functions and sensors for wind, sun, rain and temperature per channel
- Connection options for external UP/DOWN buttons and maintenance switch
- Connection option for a potential-free contact of a fire alarm system
- Individually adjustable motor runtime / reversing time
- Communication between control box and display box via 4-wire connection (4 × 0.8 mm²) RS485

PARAMETER	VALUE
Power supply	230VAC, 50 Hz
Impulse voltage withstand level	2,5 kV
Rated power	10 W
Max. switching capacity per output	250VAC, 50 Hz, 4A, $\cos \varphi \geq 0,8$ ind.
Max. total switching capacity	1380 W, 6A, 230VAC
Switching time exit	3 – 180 Sekunden oder kontinuierlich
Softwareclass	A
Conductor cross-section	
Motor connection:	0,14 mm – 2,5mm ²
Sensors/push buttons:	0,14 mm – 1,5mm ²
Operating temperature	0 °C bis +40 °C
IP class	IP 20 (Controlbox), IP 20 (Displaybox)
Degree of pollution	2 (Controlbox), 2 (Displaybox)
Battery	CR 2032
Dimensions (L × B × H):	270 × 220 × 108 mm (Controlbox) 155 × 105 × 35 mm (Displaybox)
Colour specification for standard versions	Display box: black (similar to RAL 9005) Control box: light grey (similar to RAL 7035)
Conformität	

TECHNICAL DATA

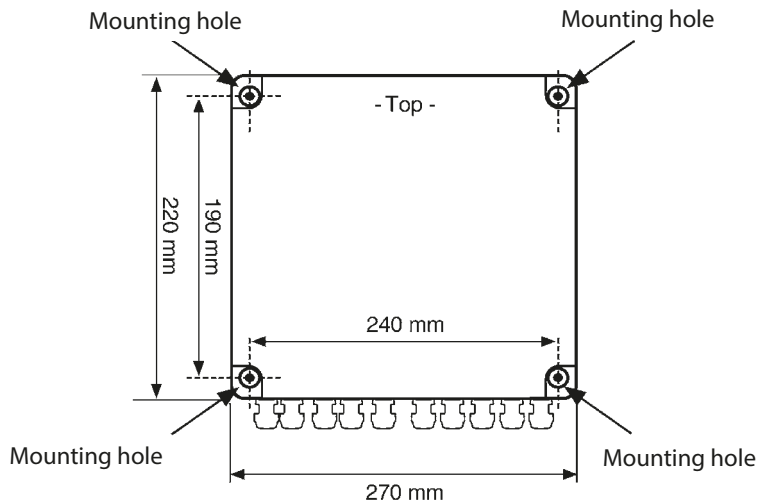

INSTALLATION / WIRING DIAGRAM

INSTRUCTIONS FOR ELECTRICIANS

- 1. Disconnect the mains supply voltage.
- 2. Loosen the screws of the housing cover, remove the control box cover and mount the housing using the outer mounting holes in the corners. Installation must be carried out so that the cable entries are located on the underside. The installation location of the control box must not be exposed to direct sunlight.
- 3. Route the connection cables through the cable entries on the underside into the housing and tighten the cable glands. Cables that are not required must be sealed. Maintain sufficient distance between mains and motor cables (230 V) and sensor/push-button cables (ELV); if necessary, bundle the cables using cable ties.
- 4. Connect the wiring according to the wiring diagram.
- 5. The output is potential-free (important when controlling central control systems).
- 6. If one or more motors (230 VAC, 50 Hz) are to be connected directly without isolating relays, a bridge must be installed between the Common terminal of the motor output and terminal L of the mains connection.
- 7. Refit the housing cover and tighten the housing cover screws.

INSTALLATION / WIRING DIAGRAM

MAINS AND MOTOR CONNECTION

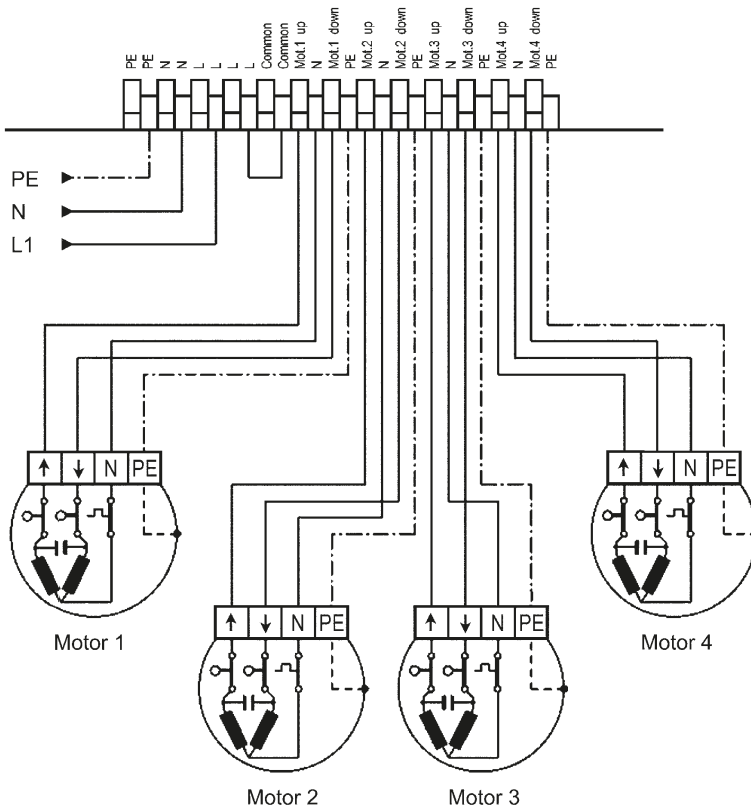
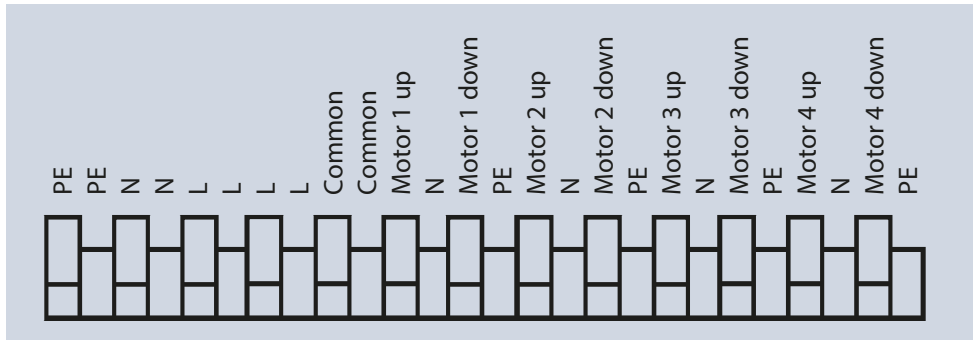

INSTALLATION / WIRING DIAGRAM

MAINS AND DECENTRALISED CONTROLS

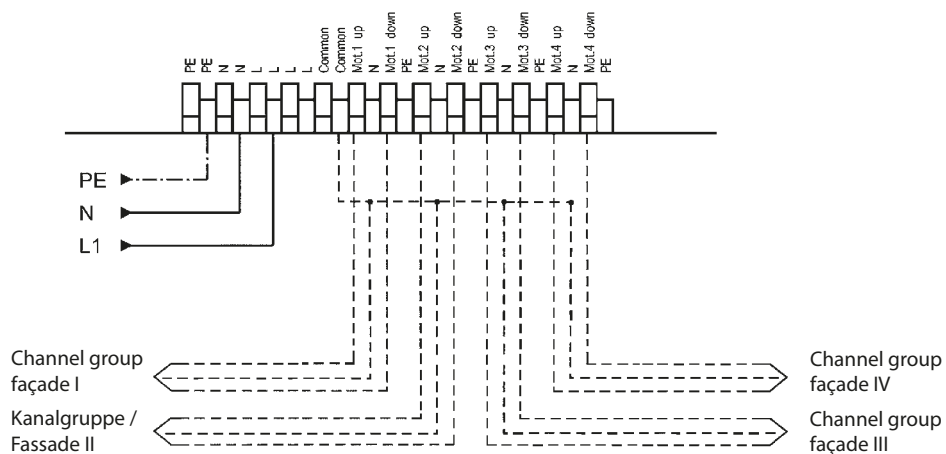
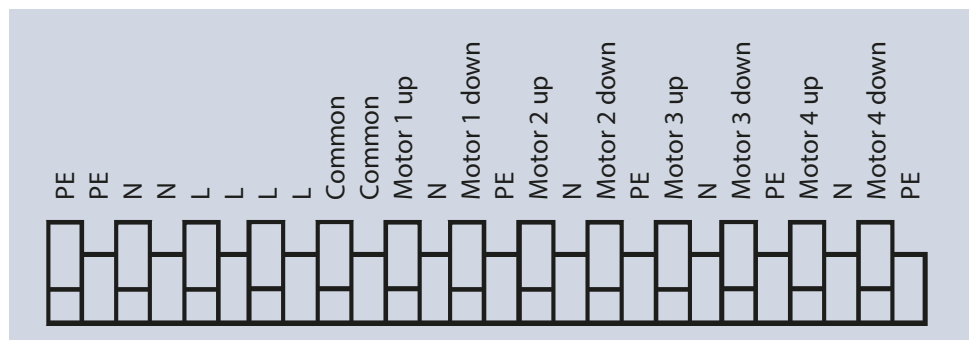

INSTALLATION / WIRING DIAGRAM

CONNECTION LUX SENSORS

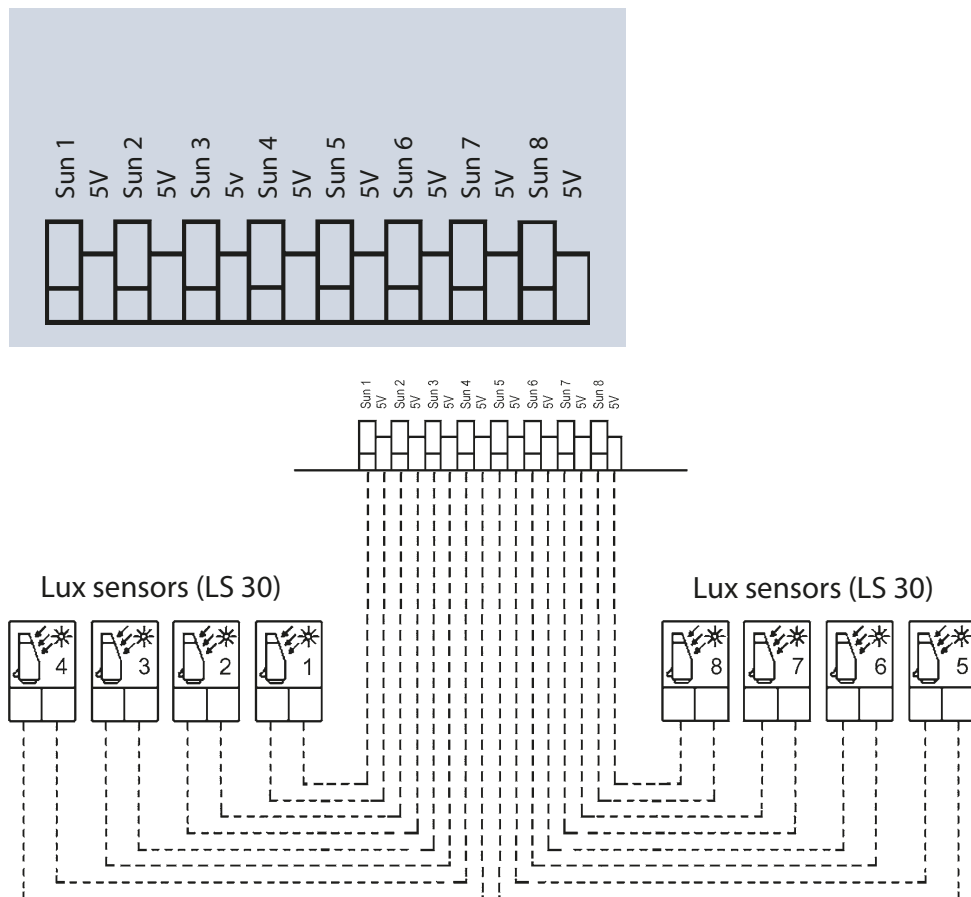

INSTALLATION / WIRING DIAGRAM

CONNECTION WIND SENSORS AND RAIN SENSORS

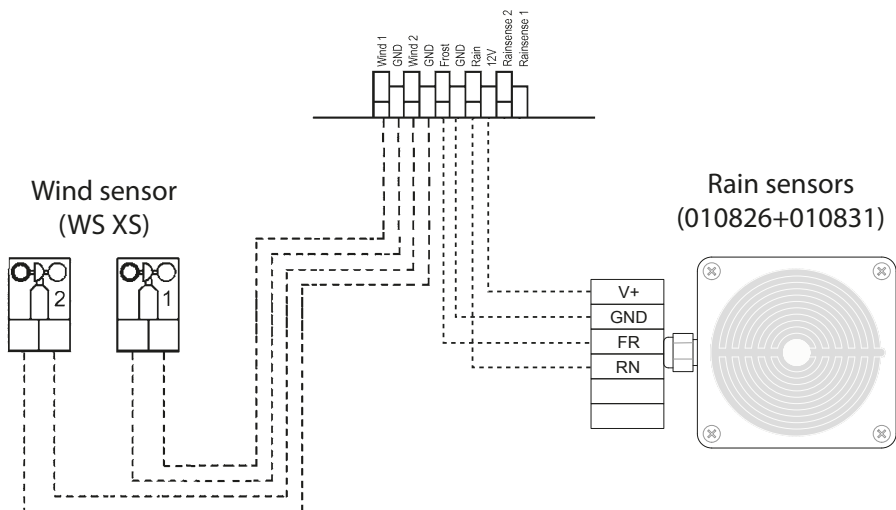
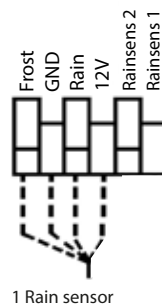
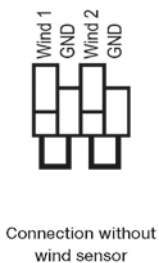
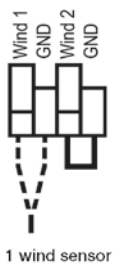
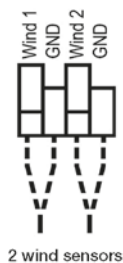
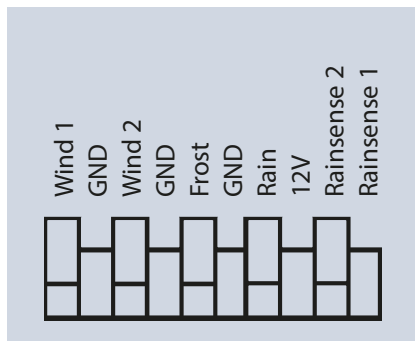

NOTE

If no wind sensor(s) is/are connected, a wire jumper must be inserted.

INSTALLATION / WIRING DIAGRAM

CONNECTION FOR EXTERNAL PUSH BUTTONS.

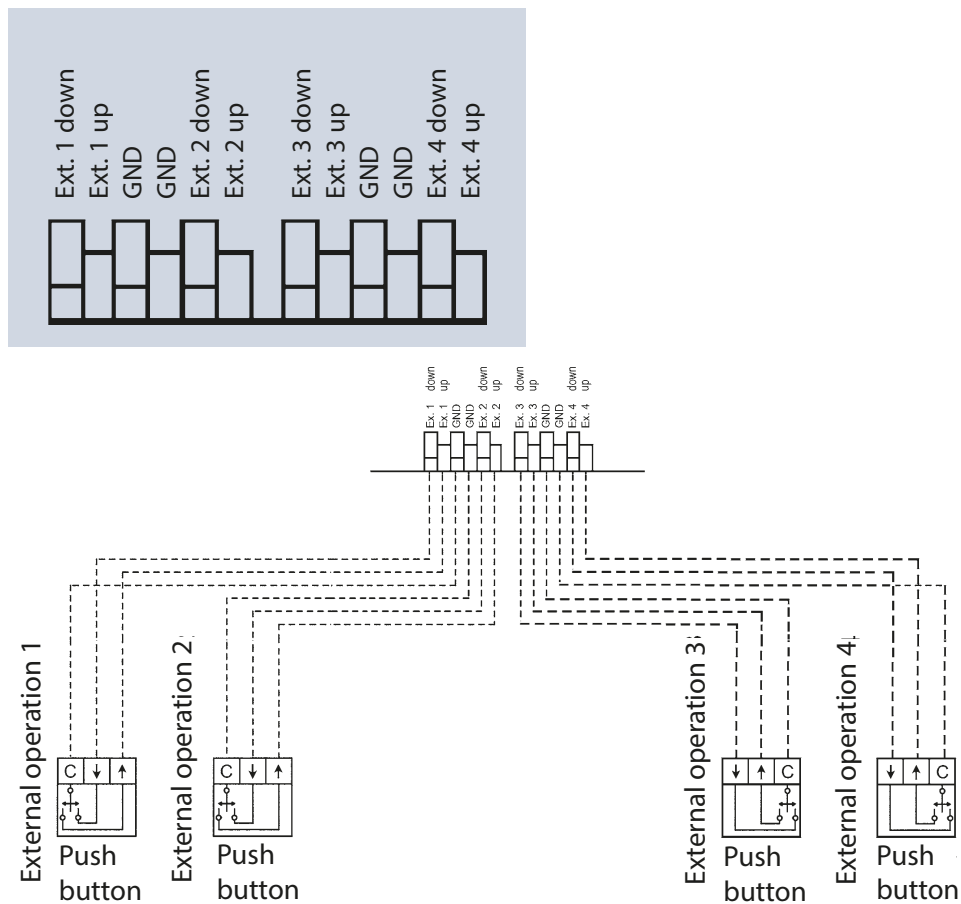

INSTALLATION / WIRING DIAGRAM

CONNECTION OF TEMPERATURE SENSORS / RADIO CLOCK

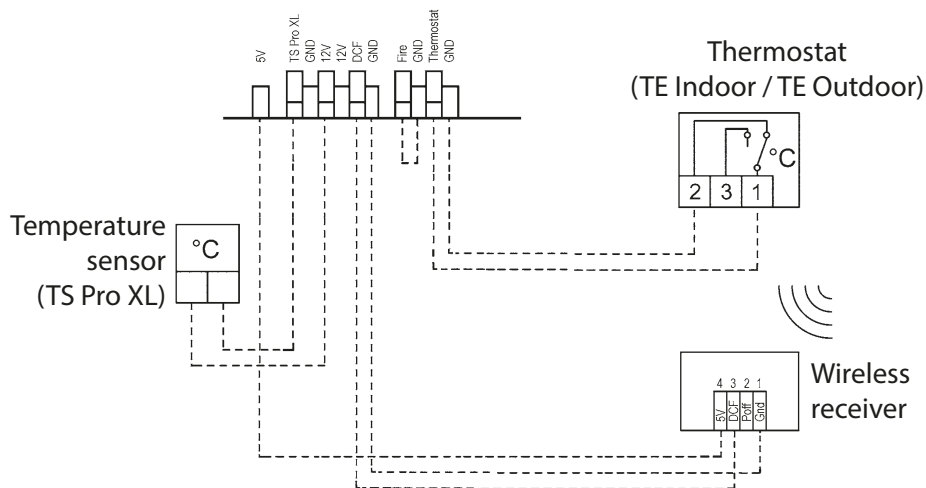
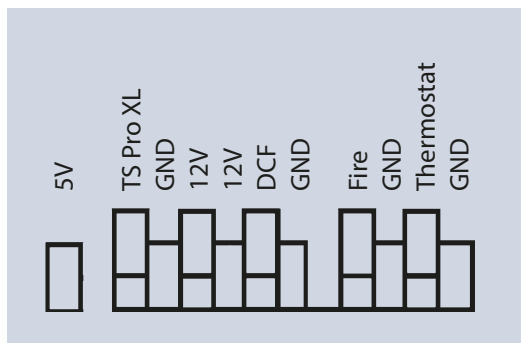

CONNECTION MAINTENANCE

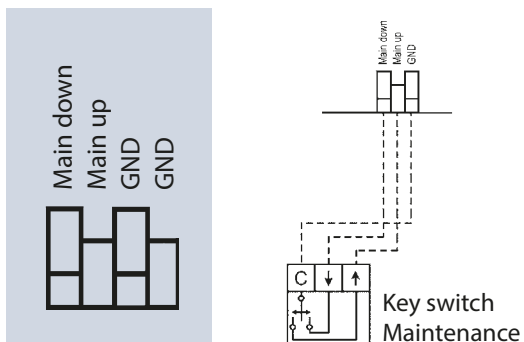

MOUNTING / CONNECTION

MOUNTING THE DISPLAY BOX

PREPARING THE MOUNTING PLATE FOR INSTALLING THE DISPLAY BOX

Remove the pre-punched cable entry in the mounting plate (see Fig. 1, red marked area) using a screwdriver, etc. Then route the connection wires of the 4-wire interface through the cable entry (see Fig. 2) of the mounting plate and mount the mounting plate accordingly.

STEP 1

Remove the pre-punched cable entry in the mounting plate (red marked area) using a screwdriver, etc.



STEP 2

Route the connection wires of the 4-wire interface through the cable entry of the mounting plate and mount the mounting plate accordingly.



CONNECTION OF THE DISPLAY BOX

- Remove the 6 screws on the rear side of the display box housing.
- Remove the housing cover.
- Use a screwdriver to break out the pre-punched cable entry (see red marked area).
- Route the cable of the 4-wire interface and connect it according to the wiring diagram (see next page).
- Refit the housing cover and fasten it again with the 6 screws.
- The display box can then be hooked into the mounting plate.



MOUNTING / CONNECTION

CONNECTION OF THE DISPLAY BOX

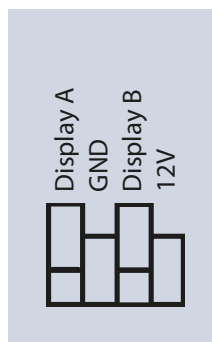

NOTE

Check the connection before commissioning.
Incorrect connection will destroy the control.

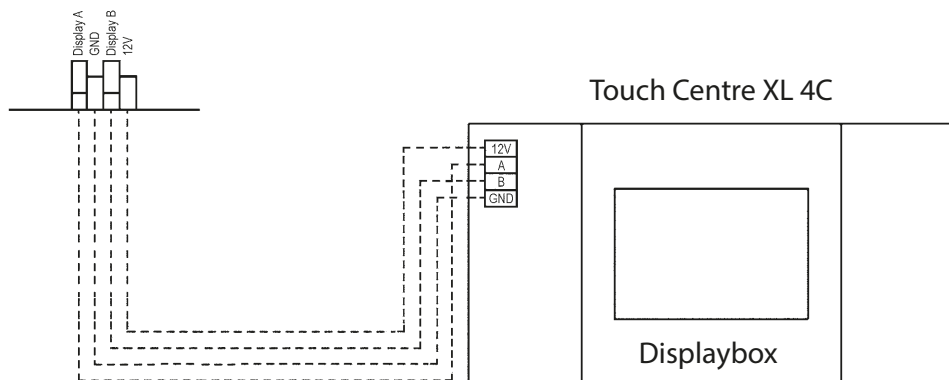

WARRANTY / MAINTENANCE

Principally, the General Terms and Conditions of the manufacturer, Vestamatic International GmbH apply. The terms and conditions are part of the sales documents and handed over to the operator upon delivery. Liability claims for personal or material damages are excluded when they can be attributed to one or more of the following causes:

- Unintended use of the product.
- Improper installation, commissioning, or operation of the product
- Non-compliance with the specifications.
- Non-observance of the safety provisions and instructions of the Operating Instructions.
- Operation of the product with improperly installed connections, defective safety devices or improperly installed safeguards.
- Modifications to the product.

This product is maintenance-free.