

VRS Switch



Art.-no.:
01820000 / 01820001

VRS Switch 1
VRS Switch 2

Art.-no.: 01820000
Art.-no.: 01820001

VRS Wall Transmitter – 1 Channel or 2 Channel.

Installation and Operating Instructions

Short description

- Universal 1- or 2-channel wall-mounted transmitter for control of VRS receivers

Scope of delivery

- Transmitter incl. mounting plate; printed cover – colour: signal white; unprinted cover – colour: signal white; mounting accessories; manual; battery CR 2032

VRS Switch 1

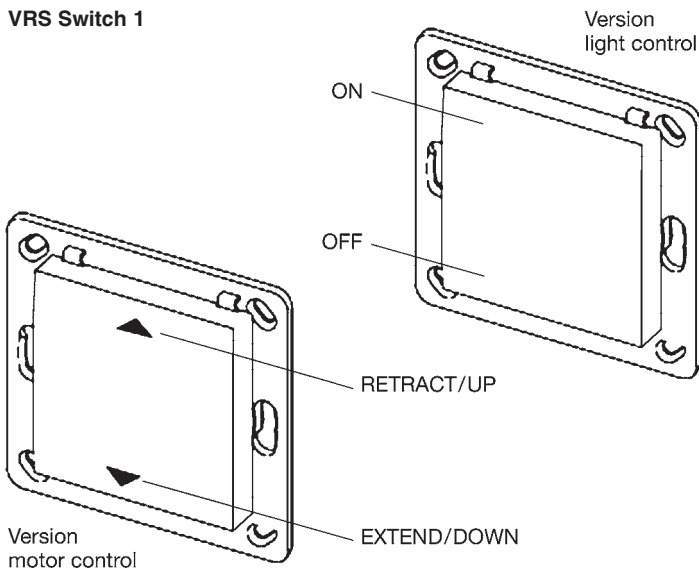

VRS Switch 2

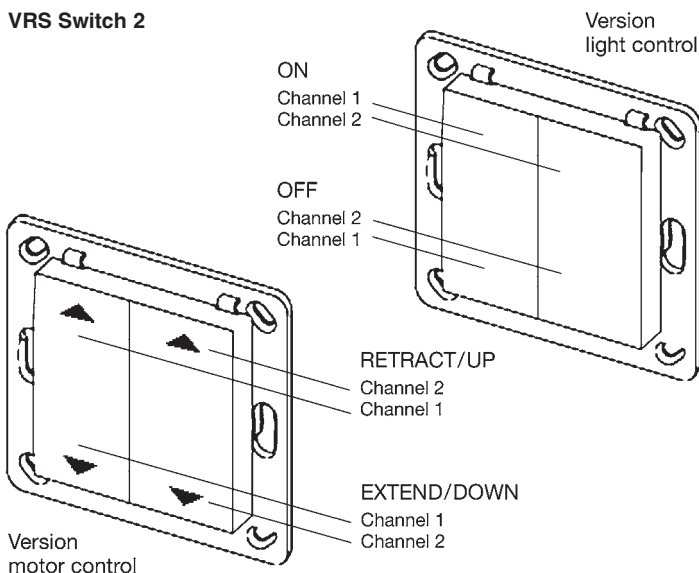

Safety precautions



- Check the VRS Wall Transmitter for signs of mechanical damage after unpacking. If you notice any shipping damage, do not start up the transmitter and notify your supplier immediately.
- The VRS Wall Transmitter should only be used for the purpose specified by the manufacturer (refer to the operating instructions). Any changes or modifications thereof are not permissible and will result in loss of all warranty claims.
- This device contains a pollutant battery. The end user must recycle all used batteries in accordance with regulation 91/157/EWG. Disposing of batteries in household waste is strictly forbidden.
- Keep batteries out of the reach of children.

Technical data

Transmitter frequency:	868 MHz
Operating temperature:	0 °C (32 °F) to +40 °C (104 °F)
IP class:	IP 30
Dimensions (L x W x H):	
VRS Wall Transmitter:	55 x 55 x 10 mm
Mounting plate :	71 x 71 x 1.5 mm
Battery:	CR2032
Colour information – Signal white:	similar RAL 9003
Nero:	similar RAL 7016 (not included)
Silver:	similar RAL 9006 (not included)
Conformity:	

Functional description

The VRS Wall Transmitter is a wireless switch transmitter for surface mounting in dry indoor rooms. It fits into the most of switch frames with the dimensions of 55 x 55 mm.

By pushing the button the VRS Code is transmitted and the connected VRS radio receivers are switched in their selected operating mode.

Disposal of waste

The disposal of electrical equipment and batteries in household waste is strictly forbidden.



The symbol (dustbin crossed out, in line with WEEE Appendix IV) indicates separate collection of electrical and electronic products in EU countries. Do not dispose of the device or battery in your household waste. Ask your town or local council about the return and collection systems available in your area to dispose of this product.

Installation / Start-up

This wall transmitter contains the following components (incl. battery + assembly kit):

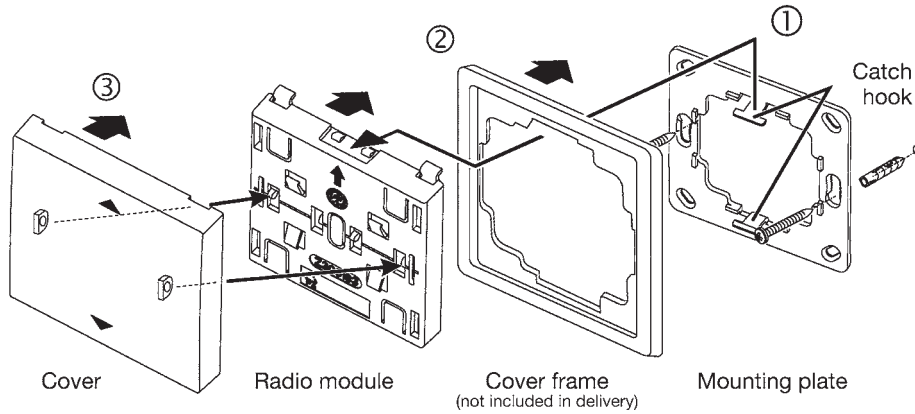

1. Screw or stick the mounting plate to the installation site with the screws and dowels or the adhesive pads.

CAUTION! Please note the chapter "Instructions for radio receivers" on the next page.

2. Place the cover frame onto the mounting plate and snap the radio module to the catches on top and bottom. **The arrow on the radio module has to point upwards.**
3. Snap the cover onto the radio module.
4. **Please read the operating instructions supplied with the receivers.**



Installation note:
While installing the wall remote, please ensure that the arrow on the back is facing the ceiling.

Replacing the battery

1. Lever off the cover and radio module.
2. Replace the battery. Only use batteries of the type CR2032. **Make sure you insert the new battery correctly, the positive pole has to be visible.**
3. Replace the cover and radio module back onto the catch hooks.

Note: The coding of the radio module is preserved even if there is no power supply. You do not need to memorize the code in the receivers again after a battery change.

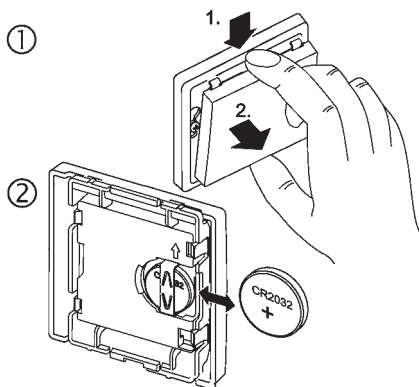

Instructions for radio receivers

ATTENTION! Radio transmission is not suitable for safety operations, such as emergency-stop, emergency call or warning signals.

Signals are transmitted across the Europe-wide approved 868 MHz frequency band. The radio transmission range largely depends on the constructional circumstances of the building. If other adjacent radio devices are simultaneously sending signals, mutual interferences cannot be debared. Such interferences can also affect individual units of a group of receivers.

Observing the following instructions will minimize these interferences:

- Avoid to mount radio receivers onto or adjacent to metal surfaces.
- Maintain minimum 50 cm clearance to consumer loads, such as microwave ovens or TV sets.
- Keep a minimum clearance of 50 cm between each mounted radio receiver.
- Keep a minimum clearance of 50 cm between a radio receiver and a radio transmitter.

If a radio-transmitted command cannot be clearly detected, the command execution will be suppressed by means of an integrated automatic safety function. The command must then be issued again.

Trouble shooting

If the radio control does not react to the receiver:

- Exchange the battery.
- Check that the wireless connection at the installation site is not impaired between the radio wall switch and the receiver.
- Memorize the transmission code in the receiver.
- Other wireless devices using the same frequency or working in direct proximity may interfere with the device.