

10.5 Sun function

With the sun function activated, the lux/twilight sensor, which is attached to the window, continuously checks the sun intensity. As soon as an individually selected sun threshold is attained, and the sun response delay has elapsed, the timer triggers the drive to move down the sunshade. The sunshade then moves down to the sensor and backs up a bit again. If the sunshade does not move down at those lighting conditions, you perceive as correct, you can easily adjust the sun intensity threshold. The sun intensity is displayed by means of a bar graph indicator. As soon as the bar undershoots the mark in the center and the response delay has elapsed, the closed sunshade will move up again. If the bar does not reach the mark in the center, the closed sunshade will move up again after the response delay has elapsed.

Threshold setting

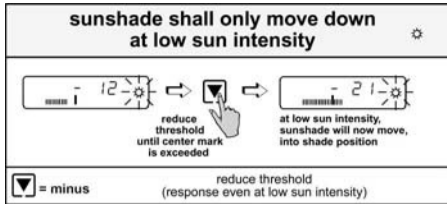

The threshold can be individually adjusted between -50 and +50.

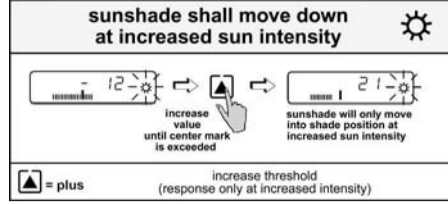

NOTE!

The sun function only operates in the automatic mode and only between the programmed up and down times. After the evening down command, the sun function is automatically disabled because the sunshade is closed. The display will indicate the moon symbol. In the automatic mode, the current sun intensity can always be indicated by touching the Info button [i] and displaying the bar graph indicator.

Response and reset delay (for the sun function)

Response and reset delay are necessary in order to prevent the sunshade from continuously moving up and down at quickly changing lighting conditions. After the sun threshold has been exceeded, the response delay will delay the downwards motion of the sunshade. The reset delay prevents the sunshade from immediately moving up after the sun threshold is undershot, e.g. due to temporary clouds.

10.6 1st Motor run time

The default 1st motor run time is set to 120 seconds by the manufacturer. This ensures, that the sunshade can be completely opened and closed. Note: Make sure to always set the motor run time longer than the actual run time of the sunshade. If the timer is used in combination with control units requiring a short-duration pulse, the motor run time is to be set to 3 seconds.

1st Reverse function

Enter a time in seconds for the reverse function. After moving all the way down, the sunshade will then move back up for those seconds you have entered and thus allows a gap position (for approx. 3 seconds or a partially open position for approx. 30 seconds by roller shutters resp. by setting of angle of venetian blinds). The sunshade will only move back up, when the preset motor run time has elapsed, thus no later than 120 seconds. Reverse function = 0.0 indicates no reverse function.

NOTE!

The reverse function must be set separately for the week program in the submenu and the day program in the main menu.

Inching mode for venetian blinds operation

When this function is enabled, the device can be controlled by pressing the button for a given time (2 seconds max.). To obtain the set duration, press the button for more than 2 seconds.

2nd Motor run time and 2nd Reverse function/Reverse time

For detailed explanation of setting the 2nd motor run time and 2nd reverse function/reverse time please see chapter 10.1.

10.7 Time / Date

The time, year and date settings are set by pressing the [▲] and [▼] buttons. Press the [□] button to go to the respective setting.

Automatic and manual daylight saving time

"ON" setting = the control automatically performs daylight saving time adjustment twice a year.

"OFF" setting = daylight saving time adjustment is disabled and can be manually set in the next sub-menu (press [□] button) by pressing the [▲] and [▼] buttons.

11. Installation of lux and twilight sensors

- Carefully pull out the display.
- Insert the plug of the lux/twilight sensor into the socket on the rear of the panel.
- Carefully push the display back into the cover frame.
- Attach the lux/twilight sensor at the desired location on the window pane.
- Activate the sun function in the menu and switch the control to the automatic mode.

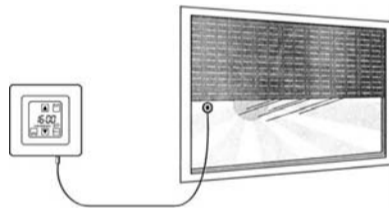

12. Locking out the display

By touching the lock-out button [□] for 3 seconds, the display can be locked out for cleaning purposes. Touch the lock-out button for 3 seconds again, in order to unlock the display.

13. Maintenance and cleaning of the touchscreen display

Please note, that the touchscreen display is a sensitive electronic device. The slightest touch on its surface will initiate a switching operation. Excessive pressing, scratching or operation with a sharp-edged object can cause irreparable damage or even destroy the display. Therefore, you should absolutely avoid touching the display surface with a pointed or sharp-edged object. Use a lens cleaning cloth to clean the touchscreen.

14. Power failure / Replacing the Battery / Restoring the control system's default settings

In the event of a power failure, all previously programmed times and settings will be stored for up to 2 years. At the start of the power failure, the display will flash for the first 10 minutes. After that, the screen will go blank. When the power supply returns, the control system will automatically display the current time. If a retract or extend command is pending during the power failure, this command will be automatically performed once the power returns. To replace the battery or restoring the control system's default settings, remove the operating device from the power pack and remove the battery from the back of the operating device. After replacing the battery, an automatic reset will be executed. This will reset the control system and restore the default settings. Everything you have programmed yourself (incl. time and date) will be deleted.

The disposal of electrical equipment and batteries in household waste is strictly forbidden.

The symbol (dustbin crossed out, in line with WEEE Appendix IV) indicates separate collection of electrical and electronic products in EU countries. Do not dispose of the device or battery in your household waste. Ask your town or local council about the return and collection systems available in your area to dispose of this product.

Vestamatic GmbH · Dohrweg 27 · D-41066 Mönchengladbach · www.vestamatic.com

Printing errors and details are subject to change without notification.

© Vestamatic GmbH

Vestamatic®

Quattro



Art.-no.:
01813400
01813200
01813110

Contents

- General
- Safety precautions
- Technical data
- Installation
- Wiring diagram
- Start-up
- Display elements
- Programming menu
- Manufacturer's default setting
- Programming details
- Installation of sun and twilight sensors
- Locking out the display
- Maintenance and cleaning of the touchscreen display
- Power failure / Replacing the Battery / Restoring the control system's default settings

1. General

The control is used for the manual and automatic control of electrically driven roller shutters and venetian blinds. The control has a wide range of program options and is produced according to high quality standards. Please read the manual carefully before starting up the device.

Slightly touching the display turns on its illumination, which will turn off automatically 20 seconds after the last operation. Every function key operation is confirmed by a short acknowledgment beep.

2. Safety precautions

- Contact a professional electrician to install the control system, because the control system requires a power supply of 230VAC, 50 Hz.
- Check the control system for signs of mechanical damage after unpacking. If you notice any shipping damage, do not start up the control system and notify your supplier immediately.
- The control system should only be used for the purpose specified by the manufacturer (refer to the operating instructions). Any changes or modifications thereof are not permissible and will result in loss of all warranty claims.
- If the control unit or the connected sunshade cannot be operated without presenting a hazard, it must be switched off and prevented from being switched on unintentionally.
- When performing work on the windows, controls or connected shades, protect them against unauthorised or unintentional operation.
- This device contains a pollutant battery. The end user must recycle all used batteries in accordance with regulation 91/157/EWG. Disposing of the batteries in household waste is strictly forbidden.

3. Technical data

Power supply:	230VAC, 50 Hz
Impulse voltage withstand level:	2.5 kV
Rated power:	2 W
Output (Up/Down):	230VAC, 50 Hz
Maximum load:	250VAC, 3A, cos φ ≥ 0.8 ind.
Align switching time down:	3 – 120 seconds
Reverse time:	0 – 30 seconds
Software class:	A
Operating temperature:	0°C (32°F) to +40°C (104°F)
Protection degree:	IP 30
Degree of contamination:	2
Battery:	CR 2032
Dimensions (L x W x H):	50 x 50 x 46 mm (without cover frame)
Colour information:	signal white (similar to RAL 9016)
Colour information Nero:	anthracite (similar to RAL 9011)
Conformity:	CE

Quattro
Quattro ZE
Quattro Nero

Art.-no.: 01813400
Art.-no.: 01813200
Art.-no.: 01813110

Shutter control for manual or automatic control of electric shutters or blind controls.

Installation and Operating Instructions

4. Installation



WARNING!
Risk of injury due to improper installation and commissioning.

Improper installation and commissioning may lead to personal injury or property damage.

Therefore:

- When connecting the device, observe the currently valid VDE standards (in particular DIN VDE 0100/0700), your local power company's regulations and the current accident prevention regulations.
- Connect the control in accordance with the wiring diagram.

Notes for professional electricians

- Switch off the power supply.
- Connect the power supply in accordance with the wiring diagram.
- Fit the power supply into a deep flush box and fix in place.
- Fit the frame cover.
- Fit the operating device into the power pack by applying gentle pressure to the frame cover.
- Switch on the power supply.
- Check the sunshade direction by using the "Up" and "Down" buttons.

5. Wiring diagram



WARNING!
The installation regulations in compliance with VDE 0100 must be observed.

When controlling multiple drives, isolating relays or suitable control units must be used.

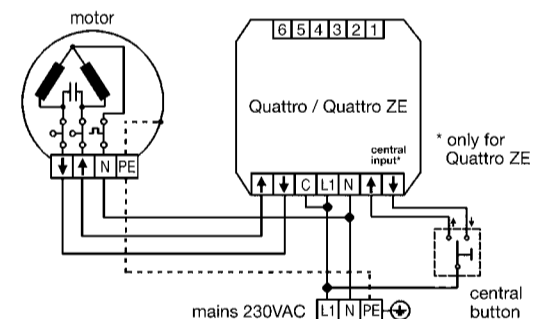

*** Note concerning the central input!**

Connection to a central input is **only** provided for Quattro ZE. While an up/down command is applied at the central button, the timer cannot issue any stop and/or opposite commands via the Quattro ZE timer. The central input can be operated both in the manual and automatic mode.



ATTENTION!

When using decentralised control systems, the wire bridge (C-L1) **must** be removed.

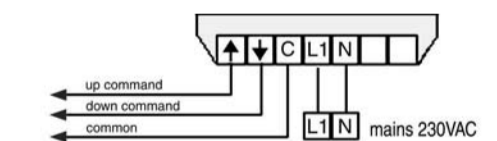

When controlling decentralised controls such as MC P2 or MC P4, for example.

6. Start-up

After installing the control and turning on the supply voltage, the control is in manual mode and ready for operation. The temperature function is still disabled but the sunshade can be operated manually with the up/down button. The Quattro ZE can also be operated via the central input. The current time, the date and additional default settings are programmed by the manufacturer (see table '9. Manufacturer's default setting') and only need to be adjusted to your personal requirements. Please touch the manual/automatic button (top left) in order to change from the manual to the automatic operation mode. The hand symbol ☞ will disappear and the button will indicate **Auto**. The sunshade will now automatically move up and down at the programmed times. Touching the "Auto" button [☞] again will change back to the manual mode. Even in the automatic mode, sunshades can always be operated with the [▲] or [▼] buttons. In order to stop moving sunshades, simply touch the opposite direction button.

Artikel-Nr.: 85601302 F1

7. Display elements

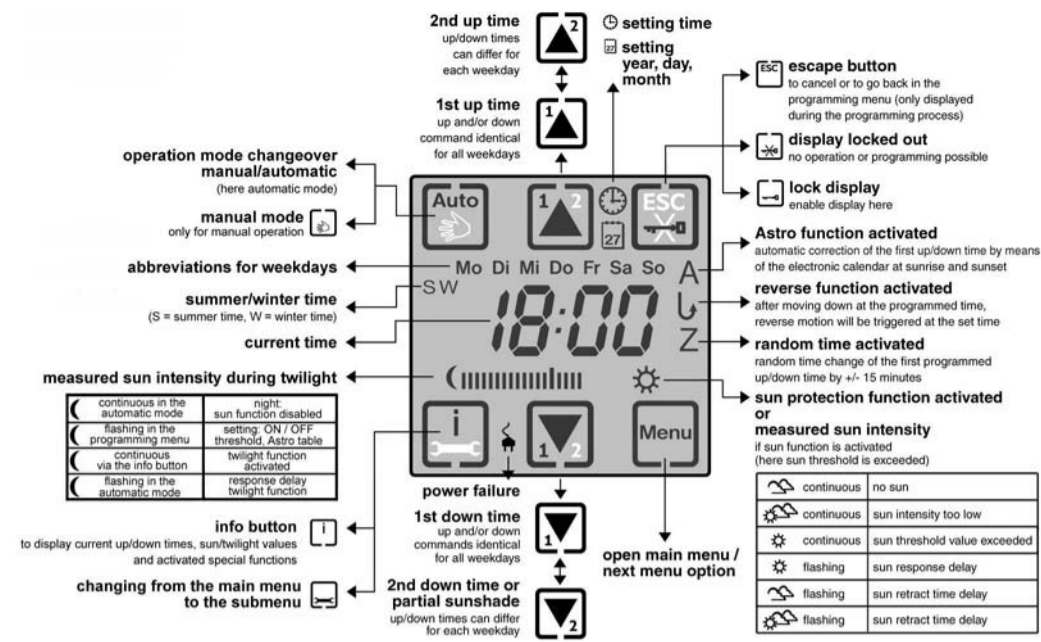

Info button

Touching the Info button [i] – only in automatic mode – will display the actual up/down times of each day, as well as all the activated special functions, such as random, Astro, reverse, sun protection and twilight function. The display indicates these functions with the corresponding symbols (Z, A, U, S, K). If either the sun or the twilight function is activated, the currently measured light intensity is displayed by means of a bar graph indicator.

8. Programming menu

The control system features a wide range of functions which can be set to meet your individual requirements. Press and hold the [Menu] button for 3 seconds to go to the main menu.

- Press the menu button [Menu] again to go to the next option on the main menu.
- In the sub-menu, press the sub-menu button [Sub] to go to a sub-menu item.
- In the sub-menu, press the sub-menu button [Sub] to go to the next sub-menu item.
- In the main/sub-menu, press the Escape button [ESC] to go back one item.
- Press and hold the Escape button [ESC] to end the programming process. Any changes made will be automatically saved.

Values can be programmed in the individual menus either by briefly pressing the [Up] and [Down] buttons for step-by-step programming, or by pressing and holding the [Up] and [Down] buttons for more than 2 seconds to scroll through the available values.

If no button is pressed for over 3 minutes in the programming menu, the programming menu will close automatically.

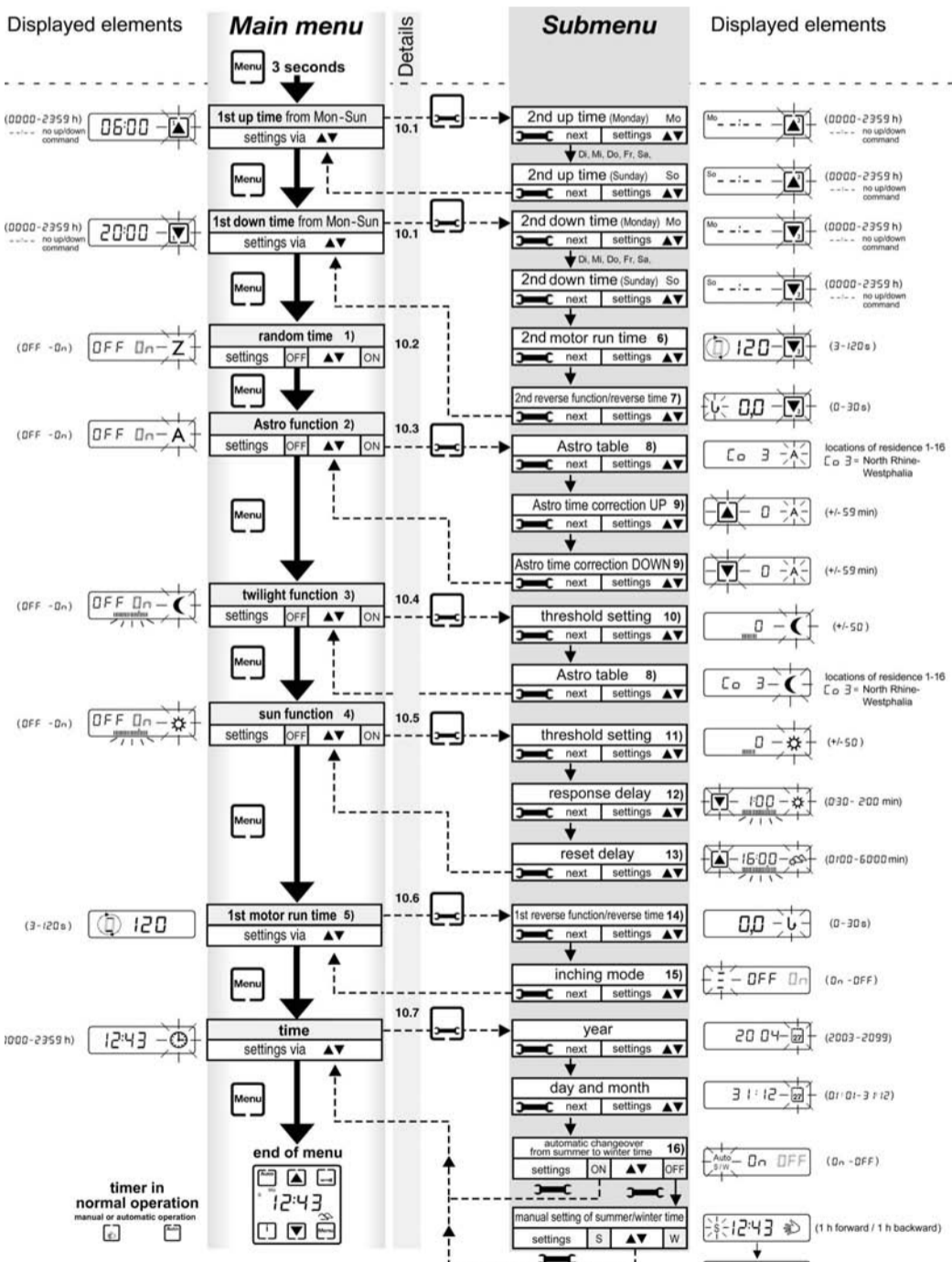

- 1) Random change of the up/down time by +/- 15 minutes
- 2) Up/down times according to sunrise and sunset times
- 3) Closing the sunshade by means of the twilight sensor
- 4) At sunshine, the sunshade moves down to the lux sensor
- 5) Time of sunshade motor triggering
- 6) Time of sunshade motor triggering – only by execution of the 2nd down time (120 sec. = complete up or down motion, 15 sec. = e.g. for partial sunshade)
- 7) Only after execution of the second down time, the sunshade shortly (0–30 sec.) moves up, e.g. for air ventilation purposes
- 8) Input of the residence as basis for Astro and twilight function
- 9) Change of the Astro times by +/-59 minutes
- 10) Setting the light intensity for the twilight function
- 11) Setting the light intensity for the sun function
- 12) Waiting time, when sunshade moves down after the sun threshold has been exceeded (required for changing lighting condition, e.g. due to clouds)
- 13) Waiting time, when sunshade moves up after the sun threshold has been undershot (prevents immediate up motion due to short obscuring by a cloud)
- 14) Only after execution of the first down time, the sunshade shortly (0–30 sec.) moves up, e.g. for air ventilation purposes
- 15) Inching mode up to 2 seconds
- 16) Summer/winter time switching automatic / manual

9. Manufacturer's default setting

Chapter	Main menu functions press button [Menu]	Sub menu functions press button [Sub]	Manufacturer's default setting	Adjustment option	Personal settings
10.1	1st Up time		daily 06:00 h	00:00 – 23:59 h	
		2nd Up time (Mo – Su)	OFF, - - - -	00:00 – 23:59 h	
10.1	1st Down time		daily 20:00 h	00:00 – 23:59 h	
		2nd Down time (Mo – Su)	OFF, - - - -	00:00 – 23:59 h	
		2nd Motor run time	120 seconds	3 to 120 seconds	
		2nd Reverse time	0.0 seconds	0 to 30 seconds	
10.2	Random time		OFF	ON / OFF	
10.3	Astro function		OFF	ON / OFF	
		Code Astro table	CO 3	CO 1 to CO 16	
		Astro time correction UP	0 minutes	-59 min. to +59 min.	
		Astro time correction DOWN	0 minutes	-59 min. to +59 min.	
10.4	Twilight function		OFF	ON / OFF	
		Threshold setting	0	-50 to +50	
		Code Astro table	CO 3	CO 1 to CO 16	
10.5	Sun function		OFF	ON / OFF	
		Threshold setting	0	-50 to +50	
		Response delay	1 minute	00:30 to 02:00 min.	
		Reset delay	16 minutes	01:00 to 60:00 min.	
10.6	1st Motor run time		120 seconds	3 to 120 seconds	
		1st Reverse time	0 seconds	0 to 30 seconds	
		Inching mode	OFF	ON / OFF	
10.7	Time / Date		current	00:00 – 23:59 hrs	
		Year	current	2003 – 2099	
		Day and month	current	01.01 – 31.12	
		Autom. summer/winter time	ON	ON / OFF	
		Manual summer/winter time	W	S / W	

10. Programming details

10.1 Up/down times (the control offers you three options to set the daily up/down times)

Day program: [Up] [Down]	Week program: [Up] [Down]	Combination of day and week program: [Up] [Down] [Up] [Down] = 4 up/down commands
On each day of the week (Mo – Su) the up/down times are identical.	Here different up/down times can be set for each day of the week.	1. On each day of the week the up/down times are identical. 2. Up/down times differ each day. The second up/down times can be set for partial sunshade without sensor.
Programming in the main menu 1st up and 1st down time	Programming in the submenu 2nd up and 2nd down time (Mo – Su)	Programming in main menu and submenu 1st up/down time and 2nd up/down times
Make sure, that the 2nd up and 2nd down time is disabled (default setting). Disabling occurs between 23:59 h and 00:00 h and is indicated as - - - - in the display.	Delete the 1st up and 1st down time in the main menu. Disabling occurs between 23:59 h and 00:00 h and is indicated as - - - - in the display.	Please be sure, the 1st up and 1st down time as well as all 2nd up and 2nd down times are programmed. In order to use the 2nd down time as partial sunshade, the motor run time is adjusted in such a way, that the sunshade only partially moves down.
	A combination of astro, random and twilight is not possible. Up/down commands will be accurately executed at the programmed time.	

2nd Motor run time

The default settings of the 2nd motor run time is set to 120 seconds by the manufacturer. This ensures, that the sunshade can be completely opened and closed. This second motor run time can also be used for partial sunshade, if not controlled by a lux sensor. For this purpose shorter motor run times need to be programmed (e.g. 15 sec.). If the partial sunshade is done by second motor run time instead of a lux sensor, the sunshade will drive also at bad weather conditions to the shade position. The 2nd motor run time will only be executed after up/down command of the 2nd up/down time.

2nd Reverse function / Reverse time (function as at the 1st reverse function, see chapter 10.6, but only after the end of the 2nd motor run time.)

10.2 Random time (can only be used for the 1st up/down time)

The random time function changes the first programmed up/down time by +/- 15 minutes and thus gives the impression of an inhabited house.

10.3 Astro function (can only be used for the 1st up/down time)

In principle, the Astro function is an electronic calendar. Depending on the programmed sunrise and sunset times, the up/down times are automatically adjusted under consideration of the geographic location of your residence (see Astro table). These will be compared to the set up/down times.

Please note:

1st programmed up time	before	the morning Astro time	sunshade moves up at Astro time	thus always at the later time
1st programmed up time	after	the morning Astro time	sunshade moves up at programmed up time	
1st programmed down time	after	the evening Astro time	sunshade moves down at Astro time	thus always at the earlier time
1st programmed down time	before	the evening Astro time	sunshade moves down at programmed down time	

By touching the info button [i] (only in automatic mode) you can always check the resulting actual up/down times of the respective day.

Astro table

A correctly working Astro function requires the input of the location of your residence due to different sunrise/sunset times throughout Europe. This input can also be used for the start of the twilight function.

Code	Area	Code	Area	Code	Area	Code	Area
1	Schleswig-Holstein, northern Lower Saxony	5	Rhineland-Palatinate, Saarland, Hesse	9	Scandinavia	13	Southern France
2	Mecklenburg-Western Pomerania	6	Saxony, Thuringia	10	Great Britain	14	Switzerland, Austria, northern Italy
3	North Rhine-Westphalia, southern Lower Saxony	7	Baden-Wuerttemberg	11	Northern France, Belgium, The Netherlands, Luxembourg	15	Spain
4	Brandenburg, Saxony-Anhalt	8	Bavaria	12	Germany	16	Southern Italy, Sicily, Corsica, Sardinia

Astro time correction UP and DOWN

According to the calendar's sunrise and sunset times but still want to use this function, you can separately correct these times for the up/down command in a range of +/- 59 minutes.

10.4 Twilight function (when sun twilight sensor is mounted)

When the twilight function is activated (ON), the sunshade will automatically move down as soon as the individually adjustable twilight threshold and/or the preset light intensity has been undershot for five minutes. Since the twilight function, whose purpose it is to prevent the sunshade from moving down too early, is activated only one hour prior to the Astro time, input of your residence's geographic region is required (see 10.3 Astro table).

NOTE!

- If the down command is executed at twilight is depended to the programmed first down time.
- If the set twilight threshold is not overshoot after one hour of the calendar sunset (astro time), e.g. in reason of too bright interior light, the sunshade will drive down automatically.

In order to prevent the programmed down times and the twilight down times from overlapping over the course of the year, we recommend to set the 1st down time at 23:00 h. This will ensure, that the sunshade always moves down at twilight.

Time of twilight	before	programmed 1st down time	sunshade moves down at twilight	thus always at the earlier time
Time of twilight	after	programmed 1st down time	sunshade moves down at programmed down time	

Threshold setting

The default twilight threshold is preset to "0" by the manufacturer and can be set in a range between -50 and +50.

Desired change	Procedure
Sunshade shall move down at brighter twilight (earlier)	⇒ Use [Up] button to increase threshold to max. +50
Sunshade shall move down at darker twilight (later)	⇒ Use [Down] button to lower threshold to max. -50