



WS XS Alu

WS XS Alu

Art.-no.: 01100410

Professional sensor devices for buildings.

Art.-no.:
01100410

Installation and Operating Instructions

Short description

- Wind sensor for measuring wind speed
- For aluminium bracket mounting

Technical data

Measuring range:	2 – 32 m/s
Electrical output:	0 – 94 Hz at 32 m/s
Contact type:	1 reed switch
Load:	max. 36 m/s, temporary
Maximum load:	5VA, max. 30 VDC, max. 0.25 A
Operating temperature:	-20°C (-4°F) to +70°C (158°F)
Material:	PC white (Macrolon 2405, UV stabilized)
Wiring cable:	5 m long, LiYY 2 × 0.34 mm ² , white
Dimensions:	H 198 mm × Ø 123 mm

Conformity:



Safety precautions



- Please note, that the wind sensor may only be used with Vestamatic control units.
- Check the wind sensor for signs of mechanical damage after unpacking. If you notice any shipping damage, do not start up the control system and notify your supplier immediately.
- The wind sensor should only be used for the purpose specified by the manufacturer (refer to the operating instructions). Any changes or modifications thereof are not permissible and will result in loss of all warranty claims.
- If the control unit cannot be operated without presenting a hazard, it must be switched off and prevented from being switched on unintentionally.
- When performing work on the windows, controls or connected shades, protect them against unauthorised or unintentional operation.

Assembly and installation



WARNING!

- When connecting the device, observe the currently valid VDE standards (in particular DIN VDE 0100/0700), your local power company's regulations and the current accident prevention regulations.

For the installation, we recommend our aluminum mounting bracket, article-no. 01100510 or mounting bracket for pole mounting (48–52 mm) article-no. 01100300.

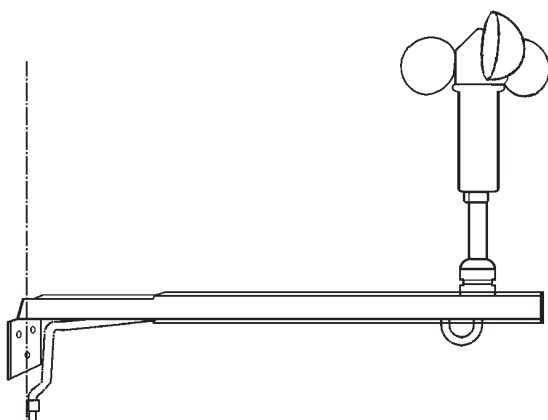

Notes for professional electricians

1. Switch off the control power supply.
2. Mount sensor in a suitable position.
3. Connect the sensor wires in accordance with the wiring diagram.
4. Switch on the control power supply.
5. Check the sensor function.

Wind speed values

Beaufort	m/s	km/h	Wind speed level
0	0–0.2	0–0.8	Calm
1	0.3–1.5	0.9–5.5	Light air
2	1.6–3.3	5.6–12.1	Light breeze
3	3.4–5.4	12.2–19.6	Gentle breeze
4	5.5–7.9	19.7–28.5	Moderate breeze
5	8.0–10.7	28.6–38.8	Fresh breeze
6	10.8–13.8	38.9–49.8	Strong wind
7	13.9–17.1	49.9–61.7	Near gale
8	17.2–20.7	61.8–74.3	Gale
9	20.8–24.4	74.4–88.0	Severe gale
10	24.5–28.4	88.1–102.4	Storm
11	28.5–32.6	102.5–117	Violent storm
12–17	32.7–56	118+	Hurricane

Cleaning

The device is almost maintenance-free. In case of excess contamination, the sensor can be cleaned with commercially available household cleaning agents without aggressive or abrasive additives.

The disposal of electrical equipment and batteries in household waste is strictly forbidden.



The symbol (dustbin crossed out, in line with WEEE Appendix IV) indicates separate collection of electrical and electronic products in EU countries. Do not dispose of the device or battery in your household waste. Ask your town or local council about the return and collection systems available in your area to dispose of this product.