



Art.-no.:
01100235

Professional wind sensor devices.

Installation and Operating Instructions

Short description

- Heated wind sensor for measuring wind speed
- With heating element for trouble-free operation during winter
- For use with the PS Classic M power supply
- Compatible with all Vestamatic central controls, awning and blind controls with the exception of Markise Plus 500 and Windwächter AP (wind monitoring device)

Installation



WARNING!

Risk of injury due to improper installation and commissioning. Improper installation and commissioning may lead to personal injury or property damage.

Therefore:

- When connecting the device, observe the currently valid VDE standards (in particular DIN VDE 0100/0700), your local power company's regulations and the current accident prevention regulations.
- Connect the control in accordance with the wiring diagram.

Safety precautions



- Contact a professional electrician to install the power supply, because the power supply requires a power supply of 230VAC, 50 Hz.
- Check the wind sensor for signs of mechanical damage after unpacking. If you notice any shipping damage, do not start up the motor and notify your supplier immediately.
- Check the wind sensor for signs of mechanical damage after unpacking. If you notice any shipping damage, do not start up the control system and notify your supplier immediately.
- If the control unit or the connected sunshade cannot be operated without presenting a hazard, it must be switched off and prevented from being switched on unintentionally.
- When performing work on the windows, controls or connected shades, protect them against unauthorised or unintentional operation.

Wiring diagram

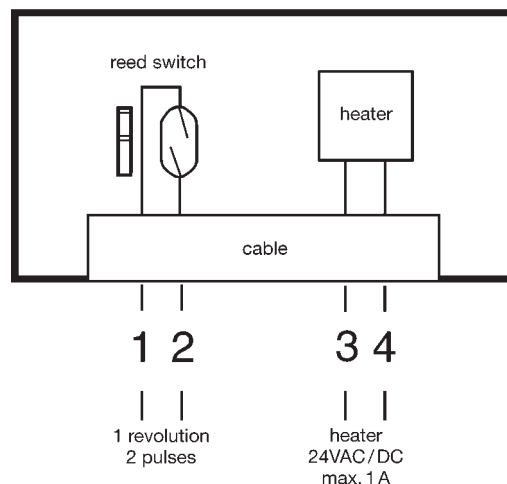

Technical data

Measuring range:	0.8 – 40 m/s
Measuring accuracy:	+/- 0.5 m/s or +/- 5% of the measured value
Electrical output:	0 – 100 Hz, typ. 2.3 Hz/ms ⁻¹
Contact type:	1 reed contact switch
Load:	max. 60 m/s, temporary
Maximum load:	10 VA, max. 42VDC, max. 0.5A
Heating:	24VAC / DC
Operating temperature:	-25 °C (-13 °F) to +60 °C (140 °F)
Material:	ABS plastic
Wiring cable:	3 m (10 ft) long, LiYY 4 x 0.25 mm ² , white
Dimensions:	H 160 mm x Ø 134 mm
Mark of conformity:	CE

Dimension diagram

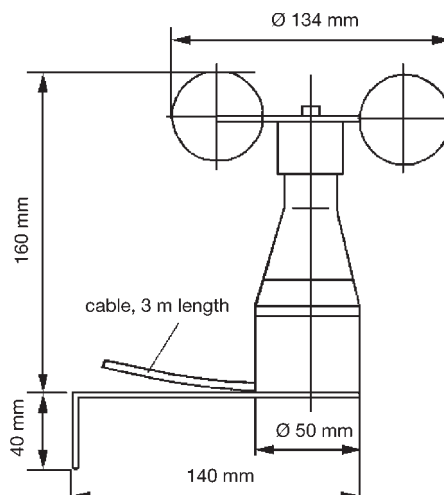

Function

The wind sensor converts wind velocity into electric signals. These signals are generated by means of a reed contact that closes under the influence of two magnets. A shaft, connected to the wind propeller and supported by sliding bearings, deflects the magnets from the reed contacts. That way, the rotational speed of the wind propeller can generate a frequency that is proportional to the wind velocity. A PTC heating element ensures trouble-free operation in the winter.



ATTENTION!

Storing, mounting and operation under weather conditions is permissible only in vertical position, otherwise water can get into the instrument.

Installation instructions

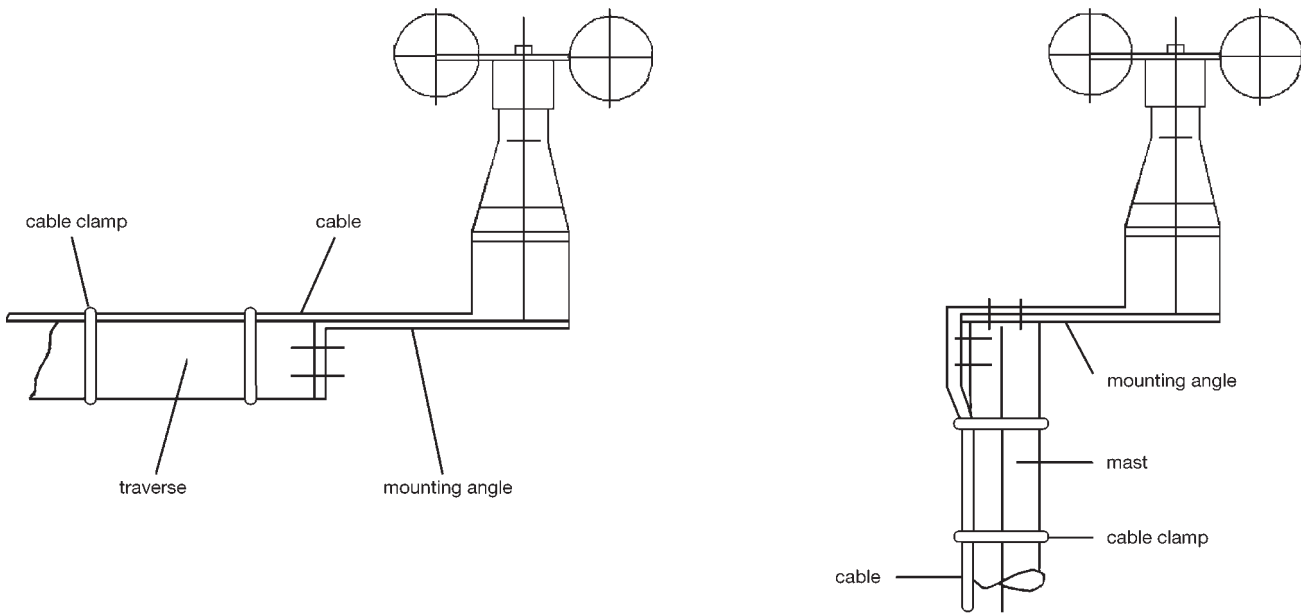

Mount the wind sensor on a cross-rail or mast with the corresponding mounting bracket. A horizontal adjustment is necessary. Attach the cable snugly with clamps or binders to cross-rail or mast in order to prevent fluttering or chafing at high wind velocities and thus the destruction of the cable.

Generally, wind metering devices should detect the wind conditions of a wide range. When measuring ground wind, the wind meter should be set up at a minimum of 10 m (33 ft) above level ground in order to receive comparable values. The distance between wind meter and obstacle must be 10 times the height of the obstacle (please refer to VDI 3786). If this requirement cannot be met, the wind meter should be set up in a height, where local obstacles cannot affect the measured values (approx. 6 – 10 m [20 – 33 ft] above the level of interference).

On flat roofs, the wind meter should be mounted in the center and not at the edge of the roof in order to avoid possible preferred wind directions.

Maintenance

Correctly installed, the wind meter runs maintenance-free. Severe environmental contamination can clog the gap between rotating and fixed parts of the wind sensor. Be sure to always keep this gap clean.

Disposal of waste

The disposal of electrical equipment and batteries in household waste is strictly forbidden.



The symbol (dustbin crossed out, in line with WEEE Appendix IV) indicates separate collection of electrical and electronic products in EU countries. Do not dispose of the device or battery in your household waste. Ask your town or local council about the return and collection systems available in your area to dispose of this product.