

1052 001 GB 2119 A01

# VL-MM-230-45



Vestaline  
M-Line motors

VL-MM-230-45/10Nm  
VL-MM-230-45/20Nm

Art.-no.: 01066043  
Art.-no.: 01066061

Vestaline motors for controlling sunshade devices or roller shutters.

## Installation and Operating Instructions

### CONTENTS

1. Safety precautions (safety measures)
2. Short description (identification of products)
3. Scope of delivery
4. Intended use
5. Technical data
6. Installation, Assembly, Disassembly
7. Troubleshooting
8. Warranty
9. Maintenance
10. Disposal of waste
11. Declaration of conformity
12. Service/Contact

### 1. Safety precautions



#### WARNING!

**Important safety information.**  
Follow these instructions to ensure the safety of persons.  
The instructions must be stored.

- Contact a professional electrician to install the motor, because the motor requires a power supply of 230VAC, 50 Hz.
- Check the motor for signs of mechanical damage after unpacking. If you notice any shipping damage, do not start up the motor and notify your supplier immediately.
- The motor should only be used for the purpose specified by the manufacturer (refer to the operating instructions). Any changes or modifications thereof are not permissible and will result in loss of all warranty claims.
- Technical data can be found on the type label of the tubular motor.
- If the motor cannot be operated without presenting a hazard, it must be switched off and prevented from being switched on unintentionally.
- When performing work on the windows, motor or connected shades, protect them against unauthorised or unintentional operation.
- Moving parts of the motor installed under 2.5m above the floor level should be protected.
- This motor is not intended for use by persons (including children) with reduced physical, sensory or mental abilities or lack of experience and/or lack of knowledge, unless they are supervised by a person responsible for their safety, or received instructions on how the device is to be used.
- Children should be supervised to ensure that they do not play with the device.
- Children are not allowed, to play with fixed controls. Keep remotes away from children.
- The installation has to be checked frequently for imbalance or of signs of wear, damaged cables or springs, if applicable.
- Automatically controlled systems have to be disconnected from the supply network, e.g. if maintenance work has to be done close to them.



#### ATTENTION!

**Pay attention to the following European guidelines:**

- Before the motor is installed, all unneeded wires must be removed and all devices which are not required for actuation with a power drive must be put out of operation.
- The actuating element of a hand release has to be installed at a height of less than 1.8 m.
- The mains cable of this device cannot be replaced. If the mains cable is damaged, the device has to be discarded.
- The cables must conform to the applicable VDE standard.
- If installing motors with a PVC H05VV-F cable, the cable on surface-mounted outdoor installations and recessed-mounted installations must be protected by a cable conduit or cable duct.
- When installing the motor an all-pole disconnection with a contact gap of at least 3 mm per pole must be provided.
- The up and down directions of the switch resp. button must be electrically or mechanically locked against each other. The changeover time for changing the running direction (up/down) must be at least 0.5 sec.



#### WARNING!

**Risk of injury due to improper installation and commissioning.**

Improper installation and commissioning may lead to personal injury or property damage.

Therefore:

- When connecting the device, observe the currently valid VDE standards (in particular DIN VDE 0100/0700), your local power company's regulations and the current accident prevention regulations.
- Connect the motor in accordance with the wiring diagram.
- It is important for the safety of professional electricians to follow the user instructions. Please keep instructions for reference.



#### ATTENTION!

- Follow the safety instructions according to EN 60335-2-97.
- Additional components for the implementation of the installation, such as adaptors and brackets must be chosen among those offered by the producer.
- When mounting the drive always use the safest and most suitable tubular motor and mounting bracket.
- For automatically actuated awnings a minimum gap of 0.4 m to other parts in the area must be maintained when the awning is fully extended. By using as an awning system the extended awning must maintain a minimum height of 1.8 m.



#### IMPORTANT!

Any screws used to fix the system must in no way touch the motor. Please refer to fig. 4.1 to 4.5.

**2. Short description**

- Motor 45 mm tube diameter
- Mechanical setting of limit positions via screws on the motor head
- 2.5 m connection cable

**5. Technical data**

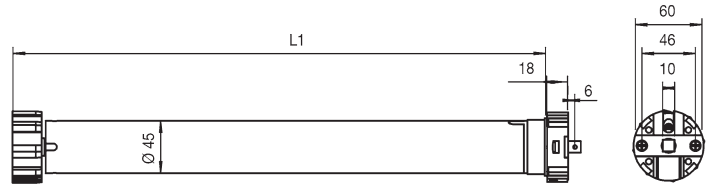

**3. Scope of delivery**

- Motor 45 mm tube diameter with 2.5 m connection cable
- Operating instructions
- Regulator
- Mounting-kit, comprising safety clip / safety cotter

Article	VL-MM-230-45/	10Nm	20Nm
	Art.-no.:	01066043	01066061
Torque (nominal)	Nm	10	20
Rated speed	rpm	15	15
Tractive power	kg	20	40
Supply voltage	VAC	230	230
Frequency	Hz	50	50
Rated power	W	112	145
Rated current	A	0.49	0.64
Running time	Min.	4	4
Protection degree	IP	44	44
Max. limit turns	turn	22	22
Length L1	mm	455	455

**4. Intended use**

These types of tubular motor described in this manual are intended solely for controlling blinds, screens or roller shutters. These types of tubular motor cannot be use in potentially explosive area.

These types of tubular motor are designed for using in a single sunshade system.

**6. Installation, assembly, disassembly**

**Wire colours of motor connection cables:**

- green/yellow: ground conductor/PE - brown: phase turning direction 1
- blue: neutral conductor/N - black: phase turning direction 2

**6.1 Wiring diagram**



**ATTENTION!**

Parallel control of more than one conventional drive motor can only be implemented by means of isolating relays.

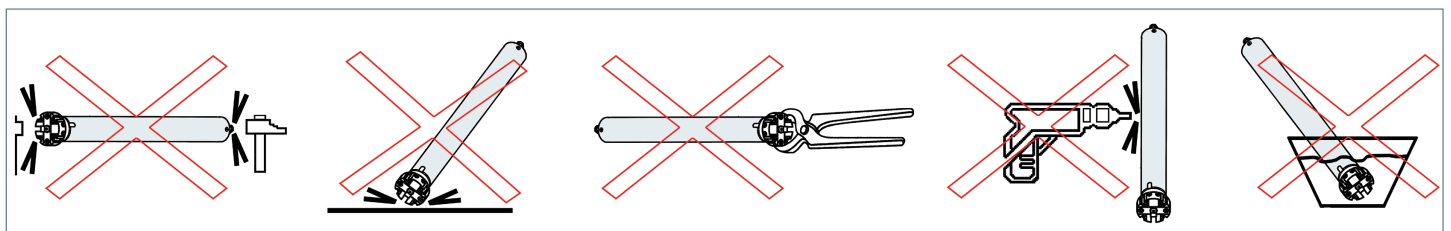
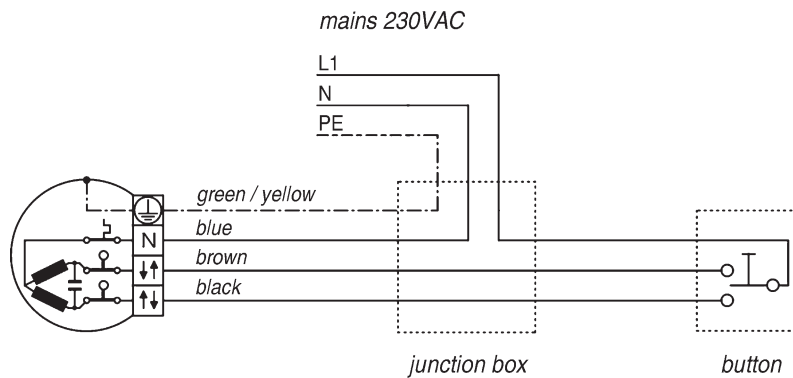

Fig. 4.1

Fig. 4.2

Fig. 4.3

Fig. 4.4

Abb. 4.5

**6.2 Assembly**

- The connection cable should be installed in an conduit to the junction box, in compliance with the local building and electrical regulations. Avoid any contact between moving objects and connection cables by routing the cables according to figure 1.
- Place the mounting bracket to the desired position. Assembly of the motor can be performed on both sides.
- Slide the adapter ring (A) on the adjustment ring (B). Be aware of the correct installation of the notch with the Adapter (D), (figure 2).
- Place the tube adapter (E) on to the motor axle (F) and secure it with the safety clip (G) that comes within the mounting-kit.
- Be careful when sliding the tubular motor completely into the tubular shaft, until the adapter ring is covered into the tubular shaft, (figure 3). Under no circumstances external force should be applied to the motor in any way.
- Place the motor head and tubular shaft into the mounting bracket and check for proper fit. Secure the square pin of the motor head with the safety cotter that comes with the mounting-kit. Make sure to install the motor in a position that the adjustment screws are accessible from the outside.

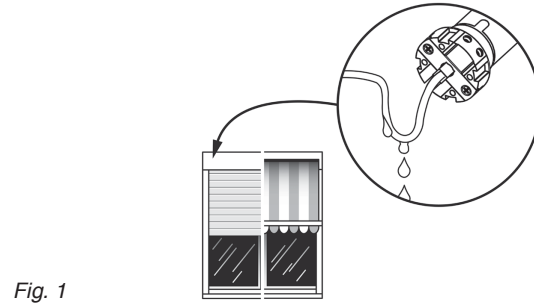

Fig. 1

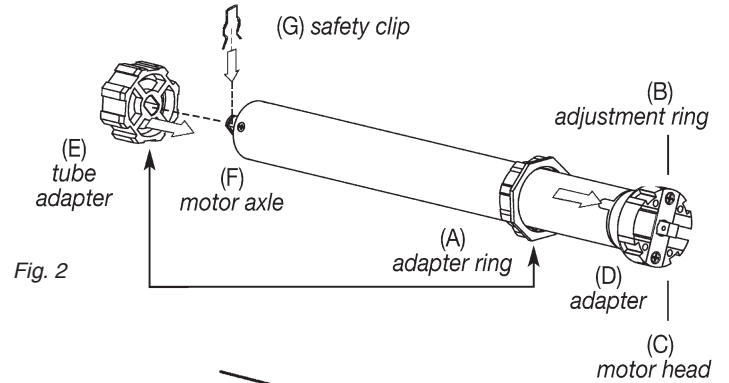

Fig. 2

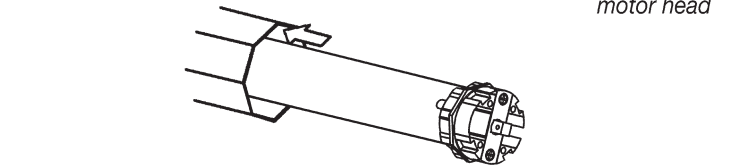

Fig. 3

**6.3 Setting the limit position switch**

The limit position switch is pre-set to about two turns of the shaft.

- Turning the adjusting screw towards the “+” increases the travel.
- Turning the adjusting screw towards the “-” decreases the travel.

Refer to the diagrams opposite to see which adjusting screw should be used for which switch-off point.

**Setting the “lower” limit position**

- Move the motor *downwards* until the automatic limit position switch independently stops the motor.
- If the pre-set limit point cannot be reached (e.g. end of material reached), move the motor *upwards* and then turn the relevant adjusting screw towards the “-” to shorten the travel. If necessary, repeat this process until the motor stops at the desired end position.
- Now turn the adjusting screw towards the “+” until the motor has reached the desired *lower* position.

**Setting the “upper” limit position**

- Move the motor *upwards* until the automatic limit position switch independently stops the motor.
- If the pre-set limit point cannot be reached (e.g. material runs into the cassette), move the motor *downwards* and then turn the relevant adjusting screw towards the “-” to shorten the travel. If necessary, repeat this process until the motor stops at the desired end position.
- Now turn the adjusting screw towards the “+” until the motor has reached the desired *upper* position.

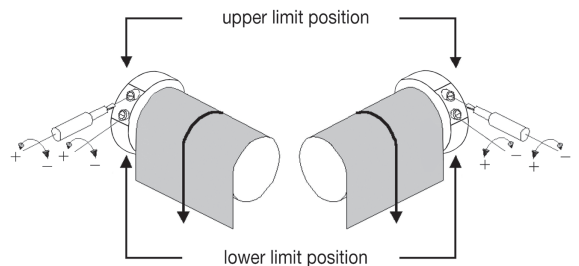
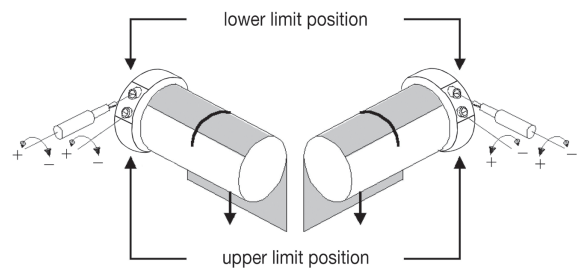

**6.4 Dissassembly**

The workflow is the same as in the section “6.2 “Assembly” but in reverse order. The setup of limit positions can be skipped.

### 7. Troubleshooting

Problem	Possible cause	Solution
■ Motor is not responding.	<ol style="list-style-type: none"> <li>1. No mains voltage.</li> <li>2. Connection error.</li> <li>3. Cutoff by internal temperature fuse.</li> </ol>	<ol style="list-style-type: none"> <li>1. Check mains voltage.</li> <li>2. Check connections (see wiring diagram).</li> <li>3. Allow the motor to cool down for 20 min.</li> </ol>
■ Motor starts slowly or makes too much noise.	<ol style="list-style-type: none"> <li>1. Connection error.</li> <li>2. Installation error or undersized motor selected.</li> </ol>	<ol style="list-style-type: none"> <li>1. Check connections.</li> <li>2. Check installation and motor load.</li> </ol>
■ Motor rotation direction is wrong.	Motor connection cables are reversed.	Disconnect the supply line from the power, and swap the black and brown conductors of the motor cable at the controller.
■ Motor stops while moving up or downwards.	<ol style="list-style-type: none"> <li>1. Preset endpoint reached.</li> <li>2. Cutoff by internal temperature fuse.</li> </ol>	<ol style="list-style-type: none"> <li>1. Set the end limits again, according to the instructions.</li> <li>2. Allow the motor to cool down for 20 min.</li> </ol>
■ Motor stops while moving upwards.	Obstacle detected.	Remove obstacle and steer the system in downward direction.

### 8. Warranty

Principally, the General Terms and Conditions of the manufacturer, Vestamatic GmbH apply. The terms and conditions are part of the sales documents and handed over to the operator upon delivery. Liability claims for personal or material damages are excluded when they can be attributed to one or more of the following causes:

- Unintended use of the product.
- Opening of the product by the customer.
- Improper installation, commissioning, or operation of the product.
- Non-compliance with the technical specifications.
- Non-observance of the safety provisions and instructions of the Operating Instructions.
- Operation of the product with improperly installed connections, defective safety devices or improperly installed safeguards.
- Modifications to the product.

### 9. Maintenance

The motor is maintenance-free.

### 10. Disposal of waste

**The disposal of electrical equipment and batteries in household waste is strictly forbidden.**



The symbol (dustbin crossed out, in line with WEEE Appendix IX) indicates separate collection of electrical and electronic products in EU countries. Do not dispose of the device or battery in your household waste. Ask your town or local council about the return and collection systems available in your area to dispose of this product.

### 11. Declaration of conformity



These products comply with the essential requirements. The Declaration of Conformity concerning these products are available on request.

### 12. Support/Contact

**Vestamatic GmbH**  
 Dohrweg 27  
 41066 Mönchengladbach  
 Germany  
 info@vestamatic.com  
 Phone: +49 2161 / 29 408-0

